

# Hydro booster systems

Custom-built solutions  
50/60 Hz

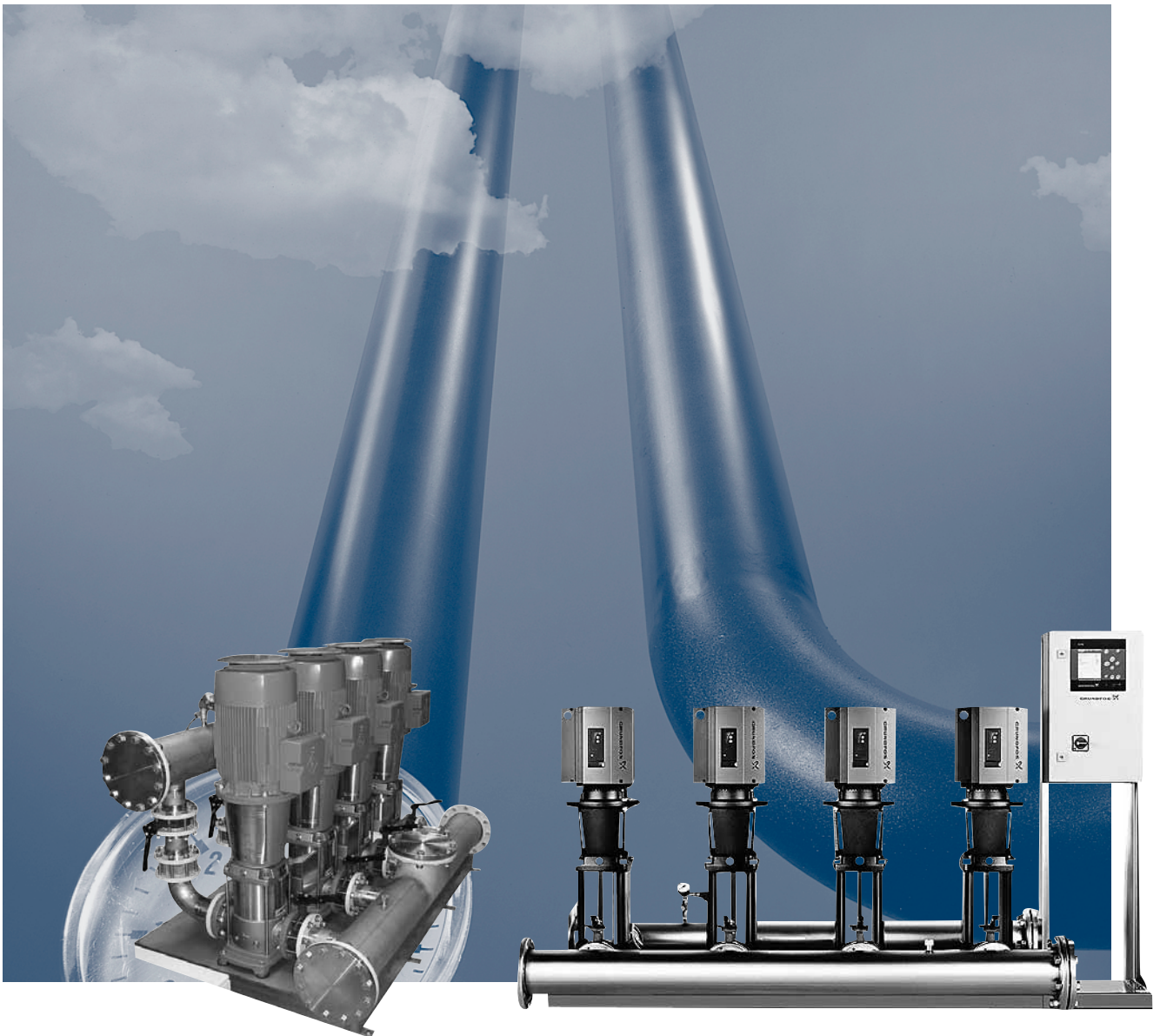

# Contents

## Introduction

Introduction	3
Custom-built Hydro booster systems	3
What are the benefits?	3

## Standard data

Hydro Multi-E	5
Hydro MPC	6

## Selection of booster systems

When to choose which booster system?	7
--------------------------------------	---

## Solutions and applications

Solutions and applications	9
----------------------------	---

## Identification

Type keys	10
-----------	----

## Applications

Water supply in building services	12
Water distribution	14
Industrial processes	16
Special installation requirements	18

## System design

Booster systems for hot-water transfer	19
Booster systems with CR low-NPSH pumps	21
Hydro booster systems for suction operation	21
Air and surge anticipation valve	22
High-pressure booster systems	24
Booster systems with alternative pumps	26
Electro-polished booster systems	28
Constructive adaptations	28
Booster systems with Harting® multiplug connection	29
Booster systems with discharge elbow manifold	29
Booster systems with alternative materials	30
Alternative control variants	31
Booster systems with alternative enclosure class (IP class)	32
Booster systems with alternative colouring	32
Alternative diaphragm tanks	33
Break tank, type VB	34
Alternative pump head positions	36
Stainless steel control cabinets	36
Control cabinets with cooling units	36
Customised nameplate	37
Threaded flange	37
OEM solutions	37
Expansion joints	37
Stainless steel mechanical filter	38

## Motor

Plug-and-pump solutions for booster systems with CR(I)E pumps	39
Booster systems with oversize motors	40
Booster systems with undersize motors	41
Booster systems with 4-pole motors	41
Hydro Multi-S with anti-condensation heater	42
Booster systems with special voltage	43
Alternative motor brands	43
cURus -, UR -, CSA approved motors	43
Other motor approvals	43

## Instrumentation

Customer-specified equipment	44
2-valve manifold	44
Swivel adapters	45
Alternative pressure transmitter	46
Flowmeter	48
Stainless steel pressure gauge	48
Sampling valve	49

## CAD drawings

CAD drawings	50
--------------	----

## Further product documentation

WebCAPS	51
WinCAPS	52

### Introduction

This catalogue is a supplement to these data booklets:

Title	Publication number
Hydro MPC, 50 Hz	96605939
Hydro MPC, 60 Hz	96605940
Hydro Multi-E, 50/60 Hz	96488673

This catalogue is intended to give you an overview of some of the many custom-built solutions which we offer for our Grundfos Hydro booster systems.

If the catalogue does not provide a solution for your specific pumping needs, please contact us with a detailed description of your requirements, and we will get down to work - for you!

### Custom-built Hydro booster systems

We offer a wide range of custom-built solutions for a wide range of demanding pressure boosting applications, such as these:

- water supply in high-rise buildings, hotels, hospitals
- water distribution in waterworks or pumping stations
- industrial processes
- irrigation.

You can choose from our made-to-stock range, mix components to create a solution or have us create an entirely unique booster system almost from scratch.

### Efficiency you can rely on

Constant pressure at all levels is a vital feature of any booster system whether installed in a multi-storey residential building or in an industrial application of any nature.

Our booster systems offer perfect constant-pressure control and will handle all variations in water consumption. Harmful peak pressures are prevented, resulting in less stress on the pipework and reduced water loss in the distribution circuit, as less water will be forced through leakages.

### Booster systems built to last

Grundfos Hydro booster systems come as complete units in superior quality designed to provide pressure boosting where additional pressure is needed. They are built on the world's number one multistage centrifugal pumps - the highly renowned CR and CRE pumps. These pumps are known for their reliability, efficiency and adaptability and form the perfect base for Grundfos Hydro booster systems. Every piece of our systems is Grundfos-made – you are thus guaranteed long-lasting technology requiring only a minimum of maintenance and providing a maximum of wire-to-water efficiency.

Furthermore, pumps from the CR range make maintenance work easy and fast, thereby saving time and money. The patented cartridge shaft seal, for example, is remarkably durable and can be replaced in a matter of minutes without special tools.

Our systems are built to last: Sturdy, compact units with easy access to all service parts.

### Big efficiency – small footprints

Booster systems with big efficiency need not be big. Our booster systems take up a minimum amount of space wherever they are placed. In other words, they have a small footprint. Furthermore, our booster systems are turnkey products; the installer simply connects the service-friendly system to water and power supply, and it's ready to go to work.

### What are the benefits?



GRA0533

Fig. 1 Hydro MPC booster system

### Rely on us for constant pressure

Whatever the demand, our Hydro booster systems provide constant pressure at all levels. Whether you require pressure boosting in residential buildings or industrial applications, Grundfos has the right solution for you! Our booster systems are famous for always maintaining the preset pressure level, thus providing optimum reliability at minimum power consumption.

### **The EFF1 motor = supersilent efficiency**

The EFF1 is the most efficient motor currently available according to the European CEMEP agreement. Grundfos leads the way by featuring EFF1 motors in our pumps as standard. All Grundfos booster systems come with this state-of-the-art piece of technology known for its extremely low noise levels and its ability to operate at high ambient temperatures.



### **High-performance hydraulics**

Choosing a Grundfos Hydro booster system is choosing a system that lives up to the highest standards when it comes to distributing potable water.

Our booster systems come in 12 flow sizes, hundreds of pressure sizes and 4 material variants ensuring that you can always find exactly the right booster system for the job.

Furthermore, the hydraulics of our booster systems are optimised to reduce pressure loss and noise. Our manifolds have rounded pipe edges (on the inner side).

Benefits:

- No gaps or cracks where corrosion can grow.
- No dead water zones.
- Reduced vortex generation.
- Reduced pressure losses.
- Reduced noise, etc.

### **From made-to-stock to completely customised**

No job is too small, no challenge too big. Our pre-defined Hydro booster range covers the booster systems most in demand. However, all elements of a Hydro booster system can be combined in a number of ways to build the perfect solution for you!

The mix-and-match approach gives you the highest level of flexibility now and in the future!

### Hydro Multi-E



GRA0533

**Fig. 2** Hydro Multi-E booster system

<b>Hydraulic data</b>	
Max. head [m]	100
Flow rate [m <sup>3</sup> /h]	0 to 80
Liquid temperature [°C]	0 to +70
Max. operating pressure [bar]	10
<b>Materials</b>	
CRE 1 to CRE 20	Stainless steel (EN/DIN 1.4301/AISI 304)
Manifold	Stainless steel (EN/DIN 1.4571/AISI 316Ti)
Non-return valves (fitted on discharge side of pumps)	Polyacetal (POM)
Isolating valves	R 1 1/4 to R 2: Brass, chrome-plated (EN/DIN 1.3433) DN 32 to 65: Stainless steel (EN/DIN 1.4581)
Pressure transmitter/gauge	Stainless steel (1.4404/AISI 316L)
<b>Optional equipment <sup>1)</sup></b>	
<ul style="list-style-type: none"> <li>• Level switch as dry-running protection</li> <li>• Pressure switches as emergency operation</li> </ul>	
<b>Accessories <sup>2)</sup></b>	
<ul style="list-style-type: none"> <li>• R100 remote control</li> <li>• CIU units</li> <li>• Level switch</li> </ul>	

<sup>1)</sup> All optional equipment, if required, must be specified when ordering the Hydro booster system, as it must be fitted from factory **prior** to delivery.

<sup>2)</sup> All accessories can be fitted on the Hydro booster system **after** delivery.

For further information about standard Hydro Multi-E booster systems, see the data booklet "Hydro Multi-E 50/60 Hz" (publication number 96488673). It is available in WebCAPS.

### Hydro MPC

Standard data



GrA0533

**Fig. 3** Hydro MPC booster system

Hydraulic data	
Max. head [m]	155
Flow rate [m <sup>3</sup> /h]	0 to 1080
Liquid temperature [°C]	0 to +70
Max. operating pressure [bar]	16
Materials	
CRI(E) 3 to CRI(E) 20	Stainless steel (EN/DIN 1.4301/AISI 304)
CR(E) 32 to CR(E) 150	Cast iron and stainless steel (EN/DIN 1.4301/AISI 304)
Manifold	Stainless steel (1.4571/AISI 316Ti) <sup>1)</sup>
Non-return valves (fitted on discharge side of pumps)	Polyacetal (POM)
Isolating valves	R 1 1/4 to R 2: Brass, chrome-plated (EN/DIN 1.3433) DN 32 to 80: Stainless steel (EN/DIN 1.4581) DN 100 to 150: Stainless steel 1.4401/AISI 316)
Pressure transmitter/gauge	Stainless steel (1.4404/AISI 316L)
Optional equipment <sup>2)</sup>	
<ul style="list-style-type: none"> <li>• Diaphragm tank</li> <li>• Redundant primary sensor</li> <li>• Dry-running protection</li> <li>• Pilot pump</li> <li>• Bypass valve</li> <li>• Position of non-return valve</li> <li>• Stainless steel non-return valve</li> <li>• Emergency operation switch</li> <li>• Repair switch</li> <li>• Isolating switch</li> <li>• Main switch with switching off of the neutral conductor</li> <li>• Operating light, system</li> <li>• Operating light, pump</li> <li>• Fault light, system</li> </ul>	<ul style="list-style-type: none"> <li>• Fault light, pump</li> <li>• Panel light and socket</li> <li>• IO 351B interface</li> <li>• Ethernet</li> <li>• GENibus module</li> <li>• CIU units</li> <li>• Transient voltage protection</li> <li>• Lightning protection</li> <li>• Phase failure monitoring</li> <li>• Beacon</li> <li>• Audible alarm</li> <li>• Voltmeter</li> <li>• Ammeter</li> </ul>
Accessories <sup>3)</sup>	
<ul style="list-style-type: none"> <li>• Dry-running protection</li> <li>• Diaphragm tank</li> <li>• Foot valve</li> </ul>	<ul style="list-style-type: none"> <li>• Machine shoe</li> <li>• Extra documentation</li> </ul>

<sup>1)</sup> Galvanised steel manifolds are available on request in some regions. For further information, contact Grundfos.

<sup>2)</sup> All optional equipment, if required, must be specified when ordering the Hydro booster system, as it must be fitted from factory **prior** to delivery.

<sup>3)</sup> All accessories can be fitted on the Hydro booster system **after** delivery.

For further information about standard Hydro MPC booster systems, see these data booklets:

- Hydro MPC 50 Hz (publication number 96605939)
- Hydro MPC 60 Hz (publication number 96605940).

Both data booklets are available in WebCAPS.

## When to choose which booster system?

The below table shows some of the issues to consider when selecting the optimum Hydro booster system.

Feature	Hydro MPC							Hydro Multi-E
	-E	-F	-S	-ED <sup>1)</sup>	-ES <sup>1)</sup>	-EF <sup>1)</sup>	-EDF <sup>1)</sup>	
<b>Hydraulic data</b>								
Max. head [m]				155				100
Max. flow rate [m <sup>3</sup> /h]				1080				87
Max. operating pressure [bar] - standard				16				10
Max. operating pressure [bar] - on request				up to 40				-
<b>Typical applications</b>								
Commercial building services (school, hotels, hospitals, blocks of flats, etc.)	●	●	●	●	●	●	●	●
Industrial applications (washing and cleaning, industrial processes, etc.)	●	○	-	●	○	●	●	-
Irrigation	-	○	●	○	○	-	○	-
<b>Motor data</b>								
Number of pumps				2-6				2-3
50 Hz range available	●	●	●	●	●	●	●	●
60 Hz range available	●	●	●	●	●	●	●	●
Motor range [kW], 50 Hz	0.37 - 55	0.55 - 55	0.37 - 55	0.37 - 55	0.37 - 55	0.55 - 55	0.55 - 55	0.37 - 5.5
Motor range [kW], 60 Hz	0.37 - 75	0.55 - 75	0.37 - 75	0.37 - 75	0.37 - 75	0.55 - 75	0.55 - 75	0.37 - 5.5
Single-phase pumps included in standard range	●	●	●	●	●	●	●	●
Three-phase pumps included in standard range	●	●	●	●	●	●	●	●
System voltage supply - 1 x 220-240 V	-	-	-	-	-	-	-	●
System voltage supply - 3 x 380-480 V	●	●	●	●	●	●	●	●
<b>Consumption profile - system recommendation</b>								
Fluctuating consumption	●	○	-	○	○	●	○	●
Stable consumption	-	-	●	-	-	-	-	-
<b>Constant pressure control</b>								
Perfect constant pressure control	●	-	-	-	-	●	-	●
A certain degree of fluctuating pressure at cut-in/-out	-	○	-	●	○	-	●	-
Fluctuating pressure at cut-in/-out	-	-	●	-	-	-	-	-
<b>Level of functionality</b>								
Medium level (stop function, constant pressure, status readings)	-	-	-	-	-	-	-	●
Advanced level (application-optimised software, energy-optimised operation, stop function)	●	●	●	●	●	●	●	-
User-defined operation of pumps possible	●	-	-	-	-	●	-	-
Highest level of security (redundant primary sensor, standby-pump allocation)	●	●	●	●	●	●	●	-
Advanced energy-saving	●	●	-	●	●	●	●	●
On/off operation	-	-	●	-	-	-	-	-
<b>Control interface</b>								
Medium-advanced interface (control panel on motor, R100, building management system)	●	●	●	●	●	●	●	●
Advanced interface (CU 351, Ethernet, building management system)	●	●	●	●	●	●	●	-
<b>Energy consumption</b>								
Rating of most energy-saving system	Perfect	Good	Standard	Good	Good	Perfect	Good	Perfect
Reading of energy consumption of specific pump	●	-	-	-	-	-	-	-

Feature	Hydro MPC							Hydro Multi-E
	-E	-F	-S	-ED <sup>1)</sup>	-ES <sup>1)</sup>	-EF <sup>1)</sup>	-EDF <sup>1)</sup>	
<b>Data communication</b>								
Control via Ethernet (built-in VNC server)	●	●	●	●	●	●	●	-
Control via building management system (via CIU units; LON, Profibus, Modbus, etc.)	●	●	●	●	●	●	●	●
<b>Miscellaneous</b>								
Complies with EMC directive	●	●	●	●	●	●	●	●
Reading of pump operating hours	●	●	●	●	●	●	●	●

<sup>1)</sup> Available on request as custom-built solution.

**Legend**

- Available/recommendation/primary application
- Second choice
- Not available/not applicable



### Solutions and applications

Solution	See page	Water supply	Water distribution	Industrial processes	Irrigation
<b>System design</b>					
Booster systems for hot-water transfer	19	○	○	●	
Booster systems with CR low NPSH	21	●	●	●	●
Hydro booster systems for suction operation	21	●	●	●	●
Air and surge anticipation valve	22	●	●		
High-pressure booster systems	24	●	●	●	
Booster systems with alternative pumps	26	●	●	●	●
Electro-polished booster systems	28	●	●	●	
Constructive adaptations	28	●	●	●	●
Booster systems with discharge elbow manifold	29	●	●	●	
Booster systems with alternative materials	30		●	●	
Booster systems with alternative enclosure class (IP class)	32	○	○	●	
Booster systems with alternative colouring	32	●	●	●	●
Alternative diaphragm tanks	33	●	○	○	
Break tank, type VB	34	●	●	○	
Alternative pump head positions	36	●	●	●	●
Stainless steel control cabinets	36	●	●	●	●
Control cabinets with cooling units	36			●	
Customised nameplate	37	●	●	●	●
Threaded flange	37	●	●	●	●
OEM solutions	37	●	●	●	○
Expansion joints	37	●	●	●	○
Stainless steel mechanical filter	38	●	●	●	●
<b>Motor</b>					
Plug-and-pump solutions for booster systems with CR(I)E pumps	39	●	●	●	○
Booster systems with oversize motors	40	●	●	●	●
Booster systems with undersize motors	41	●	●	●	●
Booster systems with 4-pole motors	41	●	●	●	
Hydro MPC-S with anti-condensation heater	42	●	●	●	●
Booster systems with special voltage	43	●	●	●	●
Alternative motor brands	43	●	●	●	●
CURus, UR- and CSA-approved motors	43	●	●	●	●
Other motor approvals	43	●	●	●	●
<b>Instrumentation</b>					
Customised equipment	44	●	●	●	○
2-valve manifold	44	○	○	●	
Swivel adapters	45	○	○	●	
Alternative pressure transmitter	46	●	●	●	●
Flowmeter	48	●	●	●	
Stainless steel pressure gauge	48	●	●	●	
Sampling valve	49	●	●	●	

- = Primary area of application.
- = Secondary area of application.

## Type keys

### Hydro Multi-E

<b>Example</b>	Hydro Multi-E 2 CRE 1-7 3 x 400/260 V
Type range	
Subgroup	
Number of pumps: 2 or 3	
Pump type	
Supply voltage	

For further information, see type key for CR(E), CRI(E), CRN(E) below.

### Hydro MPC

<b>Example</b>	Hydro MPC -E /G /NS 3 CRIE 5-8 (*) 3x380-415V, 50/60 Hz, N, PE
Type range	
<b>Subgroups:</b> Pumps with integrated frequency converter (0.37 - 22 kW) - one per pump: -E Pumps with Grundfos CUE frequency converter (30 kW and above) - one per pump: -E Pumps with external Grundfos CUE frequency converter: -F Mains-operated pumps (start/stop): -S	
<b>Manifold material</b> : Stainless steel /G: Galvanised steel /OM: Other materials	
<b>Suction manifold</b> : With suction manifold /NS: Without suction manifold	
Number of pumps with integrated frequency converter and pump type	
Number of mains-operated pumps and pump type	
Supply voltage, frequency	

\*) Code for custom-built solution.

For further information, see type key for CR(E), CRI(E), CRN(E) below.

### Type key for CR(E), CRI(E), CRN(E) pumps

<b>Example</b>	CR E 32 s -4 -2 -A -F -G -E -HQQE
Type range: CR, CRI, CRN, CRT	
Pump with integrated frequency control	
Flow rate [m <sup>3</sup> /h]	
Undersize impeller (all impellers) CR 1s, CRI 1s, CRN 1s	
Number of impellers	
Number of reduced-diameter impellers CR(E), CRN(E) 32, 45, 64, 90, 120, 150	
Code for pump version	
Code for pipe connection	
Code for materials	
Code for rubber parts	
Code for shaft seal	

### Shaft seal

<b>Example</b>	-H -Q -Q -E
Shaft seal type designation	
Material of rotating seal face	
Material of stationary seal face	
Material of secondary seal (rubber parts)	

### Key to codes

Code	Description
<b>Pump version</b>	
A	Basic version
B	Oversize motor
D	Pump with pressure intensifier
DW	Deep-well pump with ejector
E	Pump with certificate
F	Pump for high temperatures (with air-cooled top)
G	Multi-E slave
H	Horizontal version
HS	High-pressure pump with high-speed MGE motor
I	Different pressure rating
J	Pump with a different maximum speed
K	Pump with low NPSH
M	Magnetic drive
N	With sensor
P	Undersize motor
R	Horizontal version with bearing bracket
SF	High-pressure pump
V	Multi-E master
X	Special version
<b>Pipe connection</b>	
A	Oval flange
B	NPT thread
CA	FlexiClamp
CX	Triclamp
F	DIN flange
G	ANSI flange
J	JIS flange
N	Changed diameter of ports
P	PJE coupling
X	Special version
<b>Materials</b>	
A	Basic version
D	Carbon-graphite filled PTFE (bearings)
G	Wetted parts EN 1.4401/AISI 316
GI	All parts stainless steel, wetted parts EN 1.4401/AISI 316
I	Wetted parts EN 1.4301/AISI 304
II	All parts stainless steel, wetted parts EN 1.4301/AISI 304
K	Bronze (bearings)
S	SiC bearings + PTFE neck rings
X	Special version
<b>Code for rubber parts in pump</b>	
E	EPDM
F	FXM (Flouraz <sup>®</sup> )
K	FFKM (Kalrez <sup>®</sup> )
V	FKM (Viton <sup>®</sup> )

Code	Description
<b>Shaft seal type designation</b>	
A	O-ring seal with fixed driver
D	Balanced O-ring seal
H	Balanced cartridge seal with O-ring
K	Type M as cartridge seal
O	Double seal, back-to-back
P	Double seal, tandem
X	Special version
<b>Seal face material</b>	
B	Carbon, synthetic resin-impregnated
C	Other types of carbon
H	Cemented tungsten carbide, embedded (hybrid)
U	Cemented tungsten carbide
Q	Silicon carbide
X	Other ceramics
<b>Secondary seal material (rubber parts)</b>	
E	EPDM
F	FXM (Flouraz <sup>®</sup> )
K	FFKM (Kalrez <sup>®</sup> )
V	FKM (Viton <sup>®</sup> )

### Water supply in building services

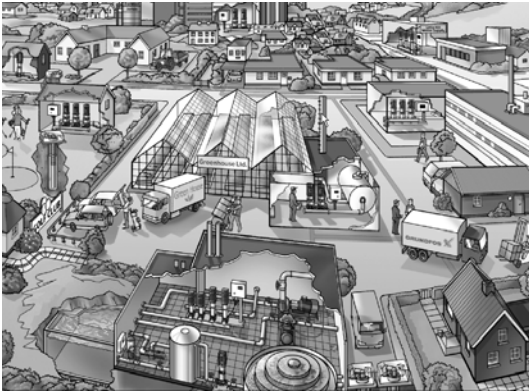

TM04 4028 0509

**Fig. 4** Water supply in building services

#### Reference applications

- High-rise buildings
- hospitals
- schools
- office buildings
- blocks of flats, etc.

#### Custom-built solutions

Water supply in buildings often expose booster systems to a variety of extreme conditions, such as the need for constant pressure at all times, long operating hours, frequent starts/stops and pressure surges.

Such conditions may result in increased wear of pump parts, such as motor bearings and shaft seal, and thus reduce the life of the pumps of the booster system.

Furthermore, the booster system must often have a very small footprint to fit the room where it is to be installed.

To avoid unexpected breakdowns and to meet your requirements, we offer custom-built solutions!

We provide solutions for applications involving the following issues:

- vacuum elimination in pipework
- special monitoring requirements
- booster systems with discharge elbow manifold, etc.

#### Vacuum elimination

Pressure fluctuations can be caused by a rapidly changing flow rate or an unstable power supply.

Example:

A booster system is installed in a high-rise building. The power supply in the building is unstable. In case of power failure, gravity will force the water column in the riser of the building to drop dramatically, thus creating a vacuum in the top of the building. When the power returns, the booster system will detect a too low discharge pressure and cut in pumps to restore the pressure up to the setpoint. In many cases, this will generate an extreme, destructive and undesired pressure pulsation in the pipe system of the building. To ensure optimum comfort in such situations, we offer custom-built solutions involving air and surge anticipation valves, Hydro MPC booster systems with speed-controlled pumps and a built-in soft pressure build-up function.



TM04 4070 0609

**Fig. 5** Air and surge anticipation valve

Air and surge anticipation valves installed on top of a high-rise building allow atmospheric air to enter and leave the pipework from the top of the building, thus reducing vacuum to an absolute minimum.

To ensure a smooth pressure build-up and a high comfort level for the persons living in the building, we also recommend a Hydro MPC-E booster system with speed-controlled pumps and soft pressure build-up function.

Speed-controlled pumps are recommended for these reasons:

- In contrast to mains-operated pumps, they will increase the discharge pressure continuously and thus reduce pressure fluctuations to a minimum.
- They will deliver the highest comfort level at tap point, as the end-user will not experience any pressure fluctuation.
- Installation costs are lower compared to systems with mains-operated pumps, as no additional valves are required.

As standard, Hydro MPC incorporates a soft pressure build-up function ensuring a smooth start-up of systems with empty pipes. Start-up takes place in two phases; a filling phase and a pressure build-up phase. This solution offers you full control of the performance and the highest possible comfort level, even in situations where vacuum is likely to occur.

### Special monitoring requirements

If you need a booster system with a high level of application-optimised functionality and flexibility, we recommend our Hydro MPC booster system which offers you a wide range of special monitoring solutions.

Among these solutions you find our booster systems with sampling valve.



TM04 3485 4508

**Fig. 6** Sampling valve

The sampling valve makes it possible to take samples of water pumped from the booster system.

We offer sampling valves that are sterilisable and thus enables testing of the microbiological and chemical quality of the water.

### Booster systems with discharge elbow manifold

Often, technical equipment must take up very little space in a building. To meet your requirement of a booster system with a small footprint, we offer custom-built booster systems with discharge elbows manifold.

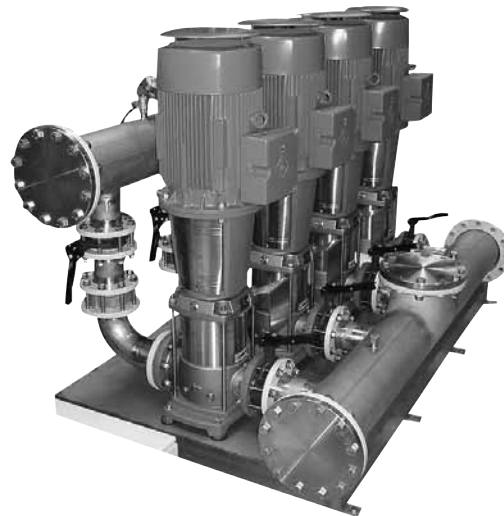

TM04 3240 3908

**Fig. 7** Booster system with discharge elbow manifold

Discharge elbow manifolds are 90 ° pipe elbows placed on the discharge side of the booster system between pump and manifold.

A booster system with discharge elbow manifolds reduce the footprint of the booster system significantly compared to booster systems with traditional manifolds.

### Further documentation

Air and surge anticipation valve	Page 22
Sampling valve	Page 49
Booster systems with discharge elbow manifold	Page 29

### Water distribution

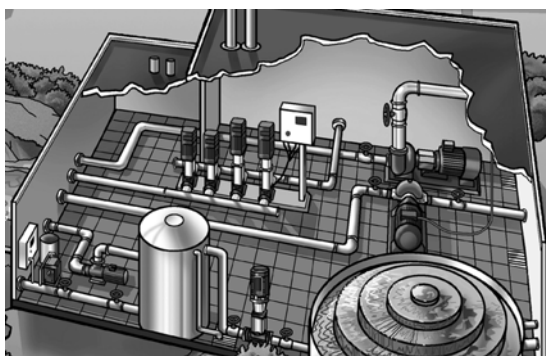

TM03 0146 4204

**Fig. 8** Water distribution from waterworks

#### Reference applications

- Waterworks
- pumping stations
- irrigation, etc.

#### Custom-built solutions

Distribution of water often exposes booster systems to a variety of extreme conditions, such as the need for 100 % reliability, strict hygienic requirements, frequent starts/stops and pressure pulsation.

To ensure comfortable and reliable water distribution, we offer custom-built solutions designed to meet your needs!

We provide solutions for applications with these requirements:

- duty points exceeding 155 m and 1080 m<sup>3</sup>/h
- a strong focus on hygiene
- cleanability, etc.

#### Duty points exceeding 155 m and 1080 m<sup>3</sup>/h

Our standard Hydro booster systems cover heads up to 155 metres and flow rates up to 1080 m<sup>3</sup>/h.

If your consumption profile exceeds these values, we offer custom-built solutions with other pump types than CR.

By choosing a custom-built booster system with alternative pumps, you will get exactly the same customer benefits in regard to quality, comfort, reliability, functionality and flexibility as with our standard solutions.

#### A strong focus on hygiene

Grundfos Hydro booster systems are **not** designed for the pumping of hygienic and sterile liquids, but their construction and the choice of materials make them an ideal solution for secondary processes in hygienic applications.

In water distribution, the quality of the pumped liquid must not be affected in any way during operation both in regard to the mechanical construction and in regard to heating of the pumped liquid.

As standard, Grundfos Hydro booster systems are designed and constructed with a strong focus on hygiene. The choice of materials and construction of hydraulic parts in the system are optimised to prevent corrosion and growth of bacteria.

The inner surface of our manifold is smooth, and rounded and TIG-welded pipe connections ensure optimum hygienic conditions free of dead water zones.



TM04 4302 1209

**Fig. 9** Manifold with optimised hygienic surface and weldings

Grundfos booster systems are based on Grundfos CR(E) and CRI(E) pumps with manifolds of stainless steel according to EN/DIN 1.4571/AISI 316Ti.

All Grundfos booster systems incorporate pumps of the dry-runner type where the pumped liquid is separated from heated parts, such as the motor, to avoid heating of the pumped liquid. If the pumped liquid comes in close contact with the motor, there is a great risk of heating the pumped liquid, resulting in a potential threat of growing bacteria such as legionella.

As standard, our booster systems are designed according to the standards below.

#### DIN 50930-6

The materials used do not affect the quality of the pumped liquid.

#### DIN 1988-2

Domestic cold water is never heated above the acceptable temperature of +25 °C during distribution.

### Cleanability



**Fig. 10** Electro-polished booster system

In some water distribution applications, it is extremely important to be able to clean the booster system sufficiently to prevent deposits from contaminating the pumped liquid.

For these secondary hygienic applications we recommend Hydro booster systems with CRN(E) pumps and all hydraulic parts of the booster system in stainless steel according to EN/DIN 1.4401.

Furthermore, we offer this type of booster system in an electro-polished version to meet strict requirements to hygiene or corrosion resistance.

#### Further documentation

Booster systems with alternative pumps	Page 26
Booster systems with alternative materials	Page 30
Electro-polished booster systems	Page 28

#### Supplementary Grundfos pumps

If the duty point exceeds 155 m and 1080 m<sup>3</sup>/h, we recommend custom-built Hydro booster systems with other Grundfos pumps, such as CR(I)E, HS, TP, NB, NK or SP.

For further information about these pumps, see WebCAPS page 51.

### Industrial processes

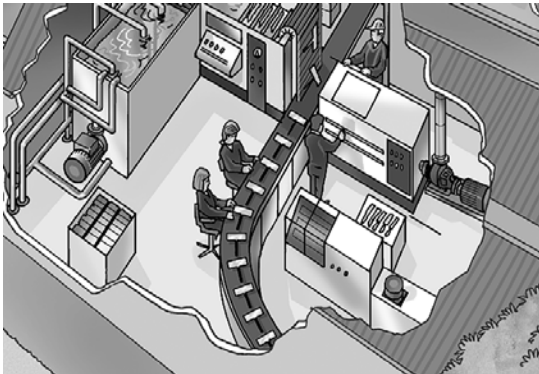

TM03 0148 4204

**Fig. 11** Industrial processes

#### Reference applications

- Electronics industry
- filtration
- washing and cleaning, etc.

#### Custom-built solutions

To ensure a safe and reliable operation in industrial processes, we offer custom-built solutions designed to meet your needs!

We provide solutions for applications involving these aspects:

- high temperature
- poor inlet conditions
- high pressure
- pumping of light chemicals
- special requirements for instrumentation.

#### High temperature

High temperature can be divided into two areas when it comes to pressure boosting:

- pumping of hot water
- pumping at high ambient temperature.

In both situations, it is crucial for a successful operation that each component is well-sized and of the right material. Otherwise, the result may be breakdown and reduced life.

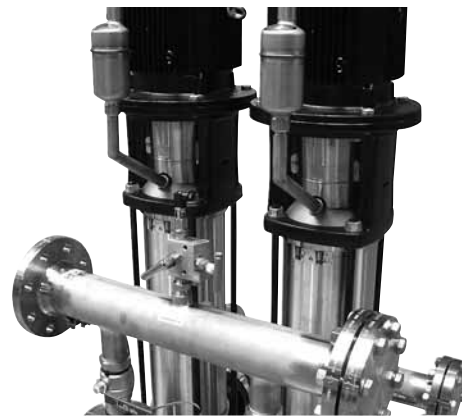

TM04 3237 3908

**Fig. 12** Hydro booster system for hot-water transfer

If you wish to pump water at a temperature higher than +70 °C, it is advisable to fit the pumps of your Hydro booster system with an air-cooled top. It is a special air-cooled seal chamber generating the same insulation effect as a vacuum flask. No external cooling is necessary; the ambient temperature is sufficient. An automatic air vent is required for venting the seal chamber.





**Fig. 13** Control cabinets with cooling units

If your booster system is to be placed at ambient temperatures close to or above +40 °C, we recommend a custom-built solution with vertical cooling units on the walls of the control cabinet. The cooling units are designed to cool electronics sufficiently to prolong their life and to avoid breakdowns.

Furthermore, we offer a wide range of other custom-built solutions, such as booster systems with oversize motors or motors with anti-condensation heaters.

### Poor inlet conditions

Cavitation can be a problem in applications where the booster system has to cope with a combination of high liquid temperatures, poor inlet pressure and/or high flow rate.

For such applications, we offer custom-built Hydro booster systems fitted with so-called CR Low-NPSH pumps which eliminate the risk of cavitation and ensure a reliable operation.

A CR low-NPSH pump is a pump with a special first stage design that reduces the pump's NPSH value and prevents erosion and destruction of pump, pipework and valves.

### High pressure

As standard, our Hydro booster systems are designed for a maximum operating pressure of 10 or 16 bar, depending on system type. Custom-built booster systems for pressures up to 40 bar are available on request.

If necessary, the pumps of the booster system are fitted with bearing flanges. A bearing flange is an additional flange with an oversize ball bearing designed to absorb axial forces in both directions, eliminating overload of the pump and thus reduced life.

### Special requirements for instrumentation

We offer a number of custom-built solutions ranging from booster systems with a 2-valve manifold for precise calibration of pressure transmitters/switches, or booster systems with sampling valves, customer-specified equipment, etc.

### Further documentation

Booster systems for hot-water transfer	Page 19
Control cabinets with cooling units	Page 36
Booster systems with oversize motors	Page 40
Hydro Multi-S with anti-condensation heater	Page 42
Booster systems with CR low-NPSH pumps	Page 21
High-pressure booster systems	Page 24
2-valve manifold	Page 44
Sampling valve	Page 49
Customer-specified equipment	Page 44

### Special installation requirements

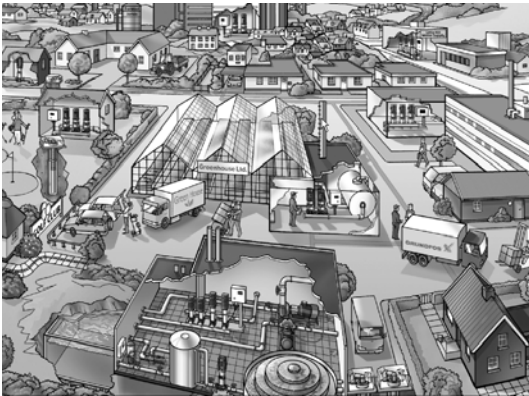

TM04 4028 0509

Fig. 14 Special applications

#### Reference applications

- Places with limited access and space
- applications in remote areas, etc.

#### Custom-built solutions

Due to safety, location and installation requirements, some installations require booster systems of special design. To meet special requirements, we offer custom-built solutions designed to meet your needs!

We provide solutions for applications involving these aspects

- constructive adaptations
- pumps with alternative mounting.

#### Constructive adaptations



TM04 3241 3908

Fig. 15 Hydro booster system with constructive adaptations

If you have special requirements for the design of your Hydro booster system, such as a larger control cabinet or special pipework, do not hesitate to contact us.

Examples of constructive adaptations are Hydro booster systems with components such as these:

- discharge elbow manifold
- bypass connection
- Harting® multiplug connection
- customer-specified pipe layout
- booster systems with alternative IP-class.

#### Pumps with alternative mounting

For installations with limited access and space, we offer booster systems with alternative mounting of pump parts such as terminal box and air vent screw.

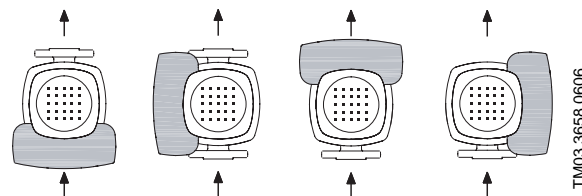

TM03 3658 0606

Fig. 16 Pumps with alternative mounting of terminal box

Example:

If a booster system is to pump hot water, safety regulations may require that the air vent screws point away from the person servicing the system. Alternatively, we offer booster systems where the pump head is turned so that the air vent screws do not point towards the service technician.

#### Further documentation

Booster systems with discharge elbow manifold	Page 29
Booster systems with Harting® multiplug connection	Page 29
Booster systems with alternative enclosure class (IP)	Page 32

### Booster systems for hot-water transfer

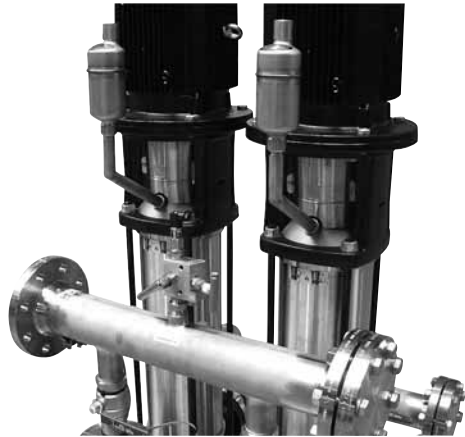

TM04 3237 3908

**Fig. 17** Hydro booster systems for hot-water transfer

If your application involve pumping of hot water at temperatures up to +120 °C, we have the right solution for you!

We offer custom-built Hydro booster systems for transfer of hot drinking water built on components such as those below.

#### CR pumps with air-cooled top

CR pumps with air-cooled top are the ideal solution when pumping hot water.

A CR pump with air-cooled top is a pump with a special air-cooled seal chamber generating the same insulation effect as a vacuum flask. No external cooling is necessary; the ambient temperature is sufficient. An automatic air vent is required for venting the seal chamber.

As standard, CR pumps with air-cooled top have a silicon carbide/silicon carbide/EPDM cartridge shaft seal, type HQQE.

**Note:** For safety reasons, it is advisable to fit a pipe in order to lead steam away from the air vent to a drain.

Local regulations must be observed.

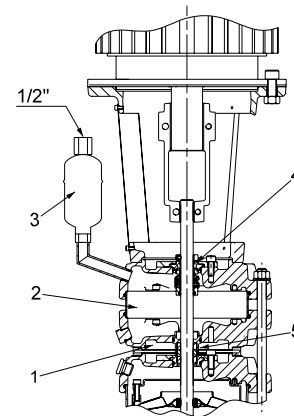

TM03 4060 3908

**Fig. 18** Sectional drawing of CR pump with air-cooled top

#### Key

Pos.	Designation
1	Seal chamber
2	Liquid
3	Air vent
4	Shaft seal
5	Cooling channel

#### Air vent positions on CR pumps with air-cooled top

As standard, the air vent of vertical CR pumps with air-cooled top is in line with the discharge port (12 o'clock position).

The possible air vent positions are shown below.

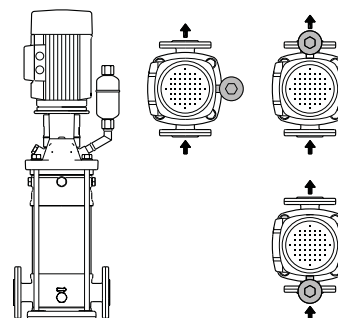

TM03 3659 0606

**Fig. 19** Air vent positions on CR pumps with air-cooled top

### Diaphragm tank



TM04 4301 1109

**Fig. 20** Diaphragm tanks

Hydro booster systems for hot-water transfer can be connected to a ROBOBRAN 200 diaphragm tank.

#### Specifications

Material	Stainless steel EN/DIN 1.4571
Capacity [l]	8 - 1000
Rated pressure [bar]	6/10 bar
Operating temperature [°C]	-50 to +200
Connection	(8 - 25 l) Pipe stub, internal thread
	(35 - 150 l) Pipe stub, external thread
	(300 - 1000 l) Flange DN 50, PN 16

#### Non-return valve

Hydro booster systems for hot-water transfer can be fitted with Gestra RK86a non-return valves.

#### Specifications

Material, body	(DN 15 - DN 100)	GX5CrNiMo19-11-2 (EN/DIN 1.4408)
	(DN 125 - DN 200)	GX5CrNiMo19-11-2 (EN/DIN 1.4408)
Material, soft seat	EPDM	
Rated pressure [bar]	10/16/25/40	
Operating temperature [°C]	-40 to +150	
Connection	DN 15 - DN 200	

#### Isolating valve

Hydro booster systems for hot-water transfer can be fitted with ARI ZESA butterfly valves.

#### Specifications

Material, body	Nodular iron
Material, seat	EPDM/NBR/FPM
Rated pressure [bar]	6/10/16
Operating temperature [°C]	-10 to +130
Connection	DN 25 - DN 350

### System size

The table shows hot-water booster systems offered by Grundfos.

Booster system	Pump type	1	3	5	10	15	20	32	45	64	90	120	150
Hydro Multi-E	CRE	•	•	•	•	•	•						
	CRIE	•	•	•	•	•	•						
	CRNE	•	•	•	•	•	•						
Hydro MPC	CR(E)	•	•	•	•	•	•	•	•	•	•	•	•
	CRI(E)	•	•	•	•	•	•						
	CRN(E)	•	•	•	•	•	•	•	•	•	•	•	•

**Note:** CRT(E) pumps are not available with air-cooled top.

For further information about CR pumps with air-cooled top, see the data booklet "CR, CRI, CRN, CRT, CRE, CRIE, CRNE, CRTE - custom-built pumps" in WebCAPS. See page 51.

## Booster systems with CR low-NPSH pumps

Cavitation is often a problem in applications where pumps have to cope with a combination of high water temperature, poor inlet pressure and/or high flow rate.

For further information about NPSH and calculation of NPSH value, see WebCAPS or these data booklets:

- CR, CRI, CRN, CRE, CRIE, CRNE
- CR, CRN high pressure
- CRT, CRTE.

We offer Grundfos booster systems with CR low-NPSH pumps designed to eliminate the risk of cavitation and to ensure a stable and reliable operation.

The CR low-NPSH pump has a special inlet design that reduces the NPSH value required by the pump and prevents erosion and destruction of the pump, pipework and valves. The improved inlet design may expose the low-NPSH pump to a more stress than conventional pumps without affecting the stability of operation.

The CR low-NPSH pump reduces excess pressure itself and does not require any additional tank to provide supplementary pressure.

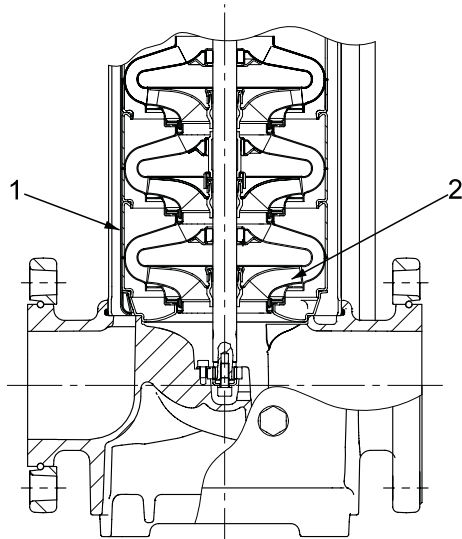

TM03 4063 1406

Fig. 21 Sectional drawing of CR low-NPSH pump

### Key

Pos.	Description
1	Special inlet part
2	Special inlet impeller

### System size

The table shows systems available with CR low-NPSH pumps.

Booster system	Pump type	1	3	5	10	15	20	32	45	64	90	120	150
Hydro Multi-E	CRE	●	●	●	●	●							
	CRIE	●	●	●	●	●							
	CRNE	●	●	●	●	●							
Hydro MPC	CR(E)	●	●	●	●	●	●	●	●	●	●	●	●
	CRI(E)	●	●	●	●	●	●	●	●	●	●	●	●
	CRN(E)	●	●	●	●	●	●	●	●	●	●	●	●

● Available

### Operating conditions for booster systems with CR low-NPSH pumps

Maximum pressure [bar]	25
Maximum water temperature [°C]	+120 *
Maximum ambient temperature [°C]	+ 40

\* With air-cooled top, the maximum water temperature is +150 °C.

For further information about CR low-NPSH pumps, see the data booklet "CR, CRI, CRN, CRT, CRE, CRIE, CRNE, CRTE - custom-built pumps" in WebCAPS.

## Hydro booster systems for suction operation

We offer custom-built Hydro booster systems for applications with suction operation.

Our solution includes:

- non-return valves on the suction side of pumps to prevent dry-running
- 1 funnel to prime the suction side of the booster system
- 1 adapter per pump (used for priming)
- 1 PTFE tube between suction manifold and discharge manifold to ensure optimum priming and suction conditions.

### System size

The table shows Hydro booster systems available for suction operation.

Booster system	Pump type	1	3	5	10	15	20	32	45	64	90	120	150
Hydro Multi-E	CRE	●	●	●	●	●							
	CRIE	●	●	●	●	●							
	CRNE	●	●	●	●	●							
Hydro MPC	CR(E)	●	●	●	●	●	●	●	●	●	●	●	●
	CRI(E)	●	●	●	●	●	●	●	●	●	●	●	●
	CRN(E)	●	●	●	●	●	●	●	●	●	●	●	●

● Available

### Product numbers

Number of pumps	Pump type	Product number
2	CRI 1, 3, 5	96052221
	CRI 10	96052222
	CRI 15, 20	96052223
	CR 32	96052224
3	CRI 1, 3, 5	96052225
	CRI 10	96052226
	CRI 15, 20	96052227
	CR 32, 45, 64, 90	96052228
4	CRI 1, 3, 5	96052229
	CRI 10	96052230
	CRI 15, 20	96052231
	CR 32, 45, 64, 90	96052232
5	CRI 1, 3, 5	96052233
	CRI 10	96052234
	CRI 15, 20	96052235
	CR 32, 45, 64, 90	96052236
6	CRI 1, 3, 5	96052237
	CRI 10	96052238
	CRI 15, 20	96052239
	CR 32, 45, 64, 90	96052240

### Air and surge anticipation valve



TM04 4070 0609

**Fig. 22** Air and surge anticipation valve

If your application involves a combination of tall buildings and unstable power supply, we have the optimum solution for you!

We offer air and surge anticipation valves as a custom-built solution for installation at the top of, for instance, a high-rise building to protect your pipework from a potential hydraulic shock.

If water is still drawn off while the booster system is stopped due to a power failure, a vacuum will form in the main riser.

When power returns, the booster system will try to make up for any water loss as fast as it can. The sudden increase in water velocity to replace the lost pressure will compress the vacuum, which will stop the liquid flow suddenly like a fast-acting valve. The surge will then pass through the liquid until it can find something to absorb the pressure created, for example a weak joint, resulting in potential flooding.

Benefits of the valve:

- The 1" Grundfos air and surge anticipation valve provides effective and controlled release of air in a vertical riser when the booster system starts up.
- It provides vacuum protection when the booster system stops and the water level in the vertical riser is lowered.
- It dampens surge pressure when the booster system starts up.
- A 1" valve with an isolating ball valve, 1" BSP female connection, 1" strainer and screwed "T" outlet (to enable flushing down to drain) will provide enough protection for a riser up to 200 mm diameter.

If a partial vacuum were to occur, the valve will take in air (through an unobstructed large orifice) filling the riser with air. When the pumps restart, the resistance of this air cushion in the riser acts to dampen the surge, resulting in the pumps slowly filling the system back up, and the valve venting the air.

The valve is WRAS-approved.

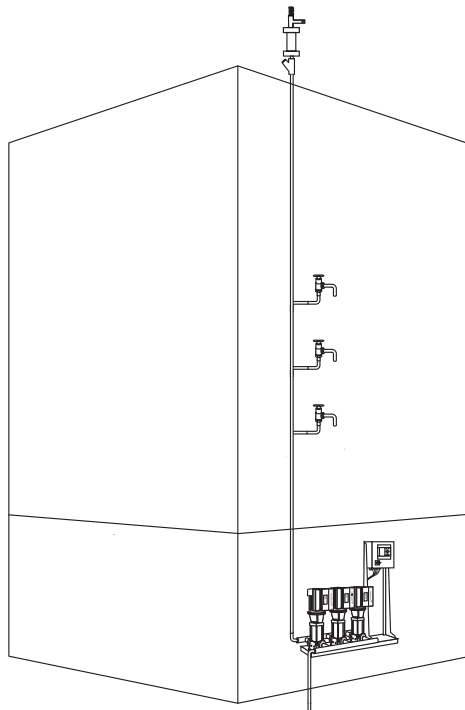

TMO4 4071 0609

Fig. 23 Air and surge anticipation valve in typical system

### System size

The table shows for which booster systems air and surge anticipation valves are available.

Booster system	Pump type	Size									
		1	3	5	10	15	20	32	45	64	90
Hydro Multi-E	CRE	●	●	●	●	●					
	CRIE	●	●	●	●	●					
	CRNE	●	●	●	●	●					
Hydro MPC	CR(E)	●	●	●	●	●	●	●	●	●	●
	CRI(E)	●	●	●	●	●					
	CRN(E)	●	●	●	●	●	●	●	●	●	●

● Available

### Dimensions

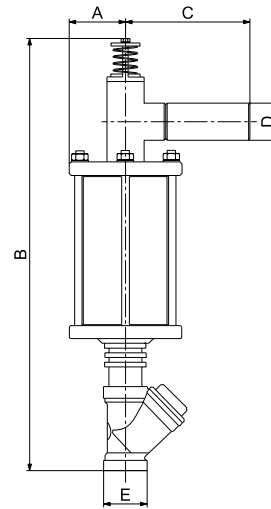

TMO4 4069 0609

Fig. 24 Dimensional sketch

Size		Pressure rating	A [mm]	B [mm]	C [mm]	D [mm]	E [mm]	Weight [kg]	Max. riser pipe diameter [mm]
mm	in.								
25	1"	PN 25	60	461 ± 3	133	1" BSP male	1" BSP female	6	200

### High-pressure booster systems



GRA0533

**Fig. 25** Hydro MPC booster system

In applications involving high operating pressures, the choice of pump parts and fittings are of top priority to prevent breakdowns or to compromise safety.

We offer custom-built solutions for operating pressures up to 40 bar.

Our solutions for high-pressure applications include high-pressure manifolds, pumps with bearing flange, high-pressure tanks and high-pressure valves.

#### Pumps with bearing flange

Grundfos pumps used for high-pressure applications are typically fitted with a bearing flange.

A bearing flange is an additional flange with an oversize ball bearing designed to absorb axial forces in both directions, ensuring long pump life and reliable operation.

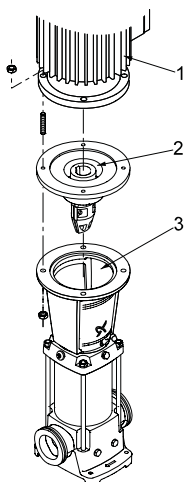

TM03 4062 1406

**Fig. 26** Bearing flange

#### Key

Pos.	Designation
1	Motor
2	Bearing flange
3	Pump head

Bearing flanges on pumps are used in two situations:

1. The pump is to operate at a higher inlet pressure than the maximum pressure recommended.
2. A standard motor with standard ball bearing is required. The bearing flange is to absorb the hydraulic load from the pump to ensure an acceptable motor bearing life.

#### Tank

Hydro booster systems for high pressure can be fitted with the tanks below.

#### Tank for operating pressures up to 25 bar

Hydro booster systems for operating pressures up to 25 bar can be fitted with "refix" DD tanks. These tanks are of the flow-through type and according to DIN 4807 T5.

#### Specifications

Material, bladder	Butyl rubber
Material, tank	Heavy-gauge steel with inner and outer epoxy coating
Material, connection	Stainless steel
Capacity [l]	8
Rated pressure [bar]	25
Temperature range [°C]	Up to +70

#### Tanks for operating pressures as from 25 bar

Hydro booster systems for operating pressures as from 25 bar can be fitted with Hydac bladder accumulators.

#### Specifications

Material, bladder	NBR rubber
Material, tank	Plastic coated stainless steel
Material, connection	Stainless steel
Capacity [l]	0.5 to 200
Rated pressure [bar]	Up to 330
Temperature range [°C]	Up to +80

#### Non-return valve

Hydro booster systems for high pressure can be fitted with the non-return valves below.

#### Gestra RK86a

#### Specifications

Material, body (DN 15 to 50)	GX5CrNiMo19-11-2 (EN/DIN 1.4408)
Material, soft seat	EPDM
Material, disc	X6CrNiMoTi17-12-2 (EN/DIN 1.4571)
Rated pressure [bar]	10/16/25/40
Operating temperature [°C]	-40 to +150
Connection	DN 15 to DN 50



## Noreva, NRV-K

### Specifications

Material, body	Stainless steel (EN/DIN 1.4057)
Material, seat	Stainless steel (EN/DIN 1.4057)
Rated pressure [bar]	63
Connection	DN 40

### Isolating valve

Hydro booster systems for high pressure can be fitted with the following isolating valves.

## Valtor

### Specifications

Material, body	Stainless steel (AISI 316)
Material, seat	PTFE
Material, ball	Stainless steel (AISI 316)
Rated pressure [bar]	40
Operating temperature [°C]	Up to 100
Connection	DN 15 to DN 100

## Danfoss-Socla, Sylax

### Specifications

Material, body	Cast iron (EN GJL-250)
Material, seat	EPDM
Material, disc	Stainless steel (AISI 316)
Rated pressure [bar]	25
Operating temperature [°C]	8 to +110
Connection	DN 50 to DN 300

### System size

The table shows for which systems we offer high pressure solutions.

Booster system	Pump type	1	3	5	10	15	20	32	45	64	90	120	150
Hydro Multi-E	CRE	●	●	●	●	●	●						
	CRIE	●	●	●	●	●	●						
	CRNE	●	●	●	●	●	●						
Hydro MPC	CR(E)	●	●	●	●	●	●	●	●	●	●	●	●
	CRI(E)	●	●	●	●	●	●						
	CRN(E)	●	●	●	●	●	●	●	●	●	●	●	●

● Available

### Booster systems with alternative pumps

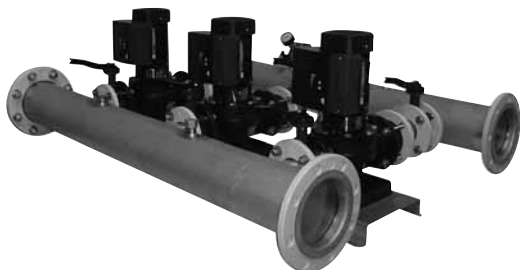

TM04 3239 3908

**Fig. 27** Grundfos booster system with alternative pumps

As standard, Hydro MPC and Hydro Multi-E booster systems are based on pumps from the CR range. Alternatively, we offer custom-built systems with other Grundfos pumps. We divide our custom-built solutions into two groups based on the level of functionality required. See below.

#### Booster systems with "Multi-E" functionality

Grundfos booster systems with "Multi-E" functionality feature the basic functionality required for water supply in commercial building services and data communication with building management systems.

We offer booster systems with "Multi-E" functionality and two to four variable-speed pumps coupled in parallel. With motor sizes from 0.37 to 7.5 kW and pump types such as these:

- TPE
- NB(G)E
- NK(G)E
- CME.

#### Benefits

##### Constant pressure

- The pumps are speed-controlled and offer 100 % adaptation to requirement.

##### High comfort level

- Our speed-controlled and high-efficiency motors reduce noise emission to a minimum and thus gives you the highest comfort level.

##### Reliability

- As every piece of our system is Grundfos-made, you are guaranteed long lasting technology that requires a minimum of maintenance.

#### Easy to install

- The booster system comes as a complete unit ready for installation. You simply connect the service-friendly system to water and power supply, and it's ready to go to work for you!

#### Small footprint

- Our booster systems take up a minimal amount of space wherever they are placed; in other words, they have a small footprint.

#### Booster systems connected to Control MPC



TM04 0210 5107

**Fig. 28** Control MPC

Grundfos booster systems connected to Control MPC feature advanced functionality, such as application-optimised software, perfect monitoring of system and individual pumps, data communication via building management systems, Ethernet communication, etc.

Grundfos Control MPC is a control cabinet with a CU 351 multi-pump controller. The CU 351 lets you control and monitor up to six pumps connected in parallel. It comes with everything you need to get started and contains a start-up wizard which guides you through a series of steps until the booster system is correctly installed and commissioned. When the installation is complete, the simple, user-friendly interface ensures that day-to-day operation is equally easy.

We offer booster systems connected to Control MPC with two to six identical pumps connected in parallel. With motor sizes from 0.37 to 630 kW and pump types such as these:

- TP(E)
- NB(G)(E)
- NK(G)(E)
- CM(E)
- HS
- SP.

### Benefits

#### Perfect adaptation

- Pumps connected to Control MPC are in a class of their own.
- All pumps are operated at individual speeds based on user-entered pump curve data. With these data, the CU 351 optimises performance and minimises energy consumption.

#### High comfort

- Every piece of the booster system is tailored to each other. The motor is a dedicated pump motor, and the Control MPC is a dedicated multi-pump controller designed to operate Grundfos pumps according to specific pump curve data.

#### Outstanding reliability

- Our systems are designed, assembled and tested by Grundfos to ensure optimum reliability.

#### Application-optimised software

- Pumps connected to Control MPC feature application-optimised software. It includes functions such as proportional pressure which is used for friction loss compensation in large pipe systems. Furthermore, you find the soft pressure build-up function which is used if your installation has an unstable power supply.

#### User-friendly interface

- Control MPC features a large LCD display with a wide range of local languages. The interface gives you a perfect overview of the performance of the system and of the individual pumps.

#### Many communication possibilities

- Compatibility of pumps connected to Control MPC:  
Ethernet (built-in VNC server is standard)  
LON 110 via CIU unit  
Profibus DP via CIU 150 unit  
Modbus RTU via CIU 200 unit  
PLC via IO 351B module.

If you want to learn more about booster systems with "Multi-E" functionality" or Control MPC functionality, please see our Hydro Multi-E or Control MPC data booklets available in WebCAPS.

### Electro-polished booster systems



TM04 3413 3908

**Fig. 29** Electro-polished booster system

We offer booster systems where all stainless steel parts of the booster system, such as pumps, base frame and manifolds, are electro-polished.

Such systems are typically used in installations where materials and surface quality must meet strict requirements to hygiene or corrosion resistance.

Electro-polishing removes burrs as well as metallic and non-metallic inclusions, providing a smooth, clean and corrosion-resistant stainless steel surface.

First all components are pickled in a mixture of nitric and hydrofluoric acid. Subsequently, the components are electro-polished in a mixture of sulphuric and phosphoric acid. Finally, the components are passivated in nitric acid.

All cast parts of CRN(E) 1, 3, 5, 10, 15 and 20 pumps are polished mechanically before being electro-polished.

**Note:** The pumps incorporate a standard shaft seal which has not been polished.

To meet the strict hygienic requirements to material and surface quality, we offer electro-polished stainless steel pumps with the following surface quality:

Pump type	Cast stainless steel	Stainless steel parts (not cast)	Surface quality
CRN(E) 1s, 1, 3, 5, 10, 15, 20	●	●	Ra ≤ 0.8 μm
CRN(E) 32, 45, 64, 90	●*)	●	Ra ≤ 15 μm Ra ≤ 0.8 μm

● Available

●\*) Pump head, pump base and pump baseplate are not electro-polished.

### System size

The table show electro-polished booster systems available.

Booster system	Pump type	1	3	5	10	15	20	32	45	64	90	120	150
Hydro Multi-E	CRE												
	CRIE												
	CRNE	●	●	●	●	●	●						
Hydro MPC	CR(E)												
	CR(E)												
	CRN(E)	●	●	●	●	●	●	●	●	●	●	●	●

● Available

### Constructive adaptations



TM04 3241 3908

**Fig. 30** Hydro booster system with constructive adaptations

If you have special requirements for the design of your Hydro booster system, such as a larger control cabinet or special pipework, do not hesitate to contact us.

Please contact us with a detailed description of your requirements, and we will get down to work - for you!

## Booster systems with Harting® multiplug connection

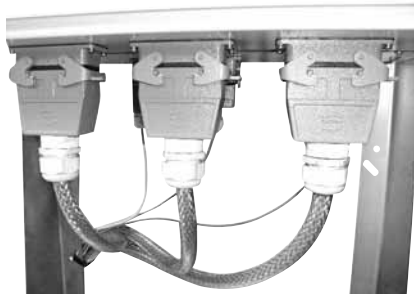

TM04 3246 3908

**Fig. 31** Harting® multi-plug used for connections in a control cabinet

We offer custom-built Hydro MPC-S booster systems with mains-operated pumps up to 7.5 kW with Harting® 10-pin multiplug connection, HAN 10 ES.

The multiplug connection means easier electrical installation and service of the booster system.

The multiplug functions as a plug-and-pump device connecting the control cabinet to the mains.

**Note:** For Hydro MPC-E or Hydro Multi-E booster systems, we offer the solution shown on page 39.

## Booster systems with discharge elbow manifold

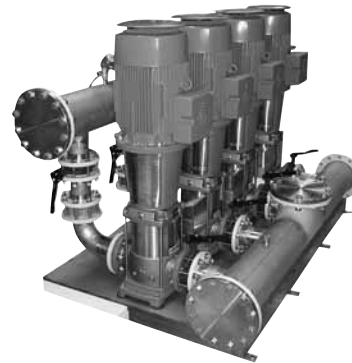

TM04 3240 3908

**Fig. 32** Hydro booster system with discharge elbow manifold

If your installation has only little space for a Hydro booster system, or if the water pumped contains air, we offer booster systems with a discharge elbow manifold.

If the water pumped contains air, a booster system with a discharge elbow manifold and pumps with air-cooled top may be the right solution for you!

For further information about air-cooled top, see page 19.

### System size

The table shows for which Hydro booster systems discharge elbow manifolds are available.

Booster system	Pump type	1	3	5	10	15	20	32	45	64	90	120	150
Hydro Multi-E	CRE		●	●	●	●	●						
	CRIE		●	●	●	●	●						
	CRNE		●	●	●	●	●						
Hydro MPC	CR(E)		●	●	●	●	●	●	●	●	●	●	●
	CR1(E)		●	●	●	●	●						
	CRN(E)		●	●	●	●	●	●	●	●	●	●	●

● Available

### Booster systems with alternative materials

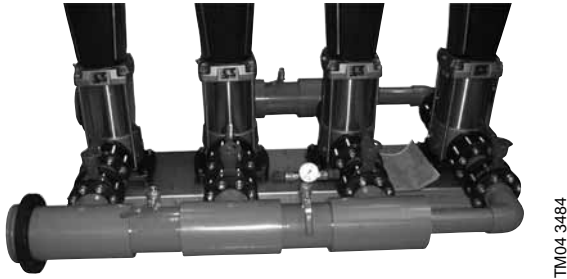

**Fig. 33** Booster system with PVC manifolds

The choice of materials for your booster system are based on factors such as these:

- concentration of pumped liquid
- liquid temperature
- operating pressure.

If your booster system is to pump liquids that do not comply with the conditions mentioned in our standard documentation, please do not hesitate to contact us.

We offer custom-built booster systems with a wide range of alternative materials.

#### Manifolds

Our custom-built solutions include manifolds made of aluminium, PVC and other materials.

#### Pumps

We offer custom-built booster systems with the following pump material variants:

#### CR(E), CRI(E)

- For liquid transfer and pressure boosting of water within a temperature range of 0 to +70 °C.
- CRE, CRIE: If the flow rate fluctuates over time.

#### CRN, CRN(E)

- For systems where all parts in contact with the water must be of high-grade stainless steel, for instance when pumping technical water, softened water or deoxidised water.
- CRNE: If the flow rate fluctuates over time.

#### CRT, CRTE

- For saline liquids or if your booster system is installed in an aggressive or maritime environment.
- CRTE: If the flow rate fluctuates over time.

For further information about CR material variants, see the data booklet "CR, CRI, CRN, CRE, CRIE, CRNE" in WebCAPS.

### Alternative control variants



GrA0633

**Fig. 34** Hydro MPC

As standard, Hydro MPC booster systems are available with three control variants. For further information about control variants, see the data booklet "Hydro MPC" in WebCAPS.

#### Hydro MPC-E

Two to six electronically speed-controlled pumps.

From 0.37 to 22 kW, Hydro MPC-E is fitted with CR(I)E pumps with integrated frequency converter.

From and above 30 kW, Hydro MPC-E is fitted with CR pumps connected to external Grundfos CUE frequency converters (one per pump).

#### Hydro MPC-F

Booster systems with two to six CR(I) pumps connected to one external Grundfos CUE frequency converter. The speed-controlled operation alternates between the pumps of the booster system.

#### Hydro MPC-S

Booster systems with two to six mains-operated CR(I) pumps.

#### Alternative control variants

If your application requires an alternative control variant, we can offer the following control variants.

#### Hydro MPC-ED

Booster systems with two CR(I)E pumps and one to four mains-operated CR(I) pumps.

#### Hydro MPC-ES

Booster systems with one CR(I)E pump and one to five mains-operated CR(I) pumps.

#### Hydro MPC-EF

Booster systems with two to six CR(I) pumps connected to external Grundfos CUE frequency converters (one per pump).

If possible, the Grundfos CUE frequency converters will be mounted inside the control cabinet.

#### Hydro MPC-EDF

Booster systems with two CR(I) pumps connected to external Grundfos CUE frequency converters and one to four mains-operated CR(I) pumps.

If possible the external Grundfos CUE frequency converters will be mounted inside the control cabinet.

## Booster systems with alternative enclosure class (IP class)

The enclosure class states the degrees of protection of the motor against ingress of solid objects and water.

We offer motors and control cabinets with alternative enclosure class (IP class).

As standard, our motors and control cabinets meet the following requirements:

Motors on CR, CRI: IP55

Motors on CRE, CRIE: IP54

Control cabinets: IP54

On request, we offer booster systems with enclosure classes up to IP65.

IP class	Description
IP54	<ul style="list-style-type: none"> <li>The motor is protected against the ingress of dust, i.e. harmful layers of dust.</li> <li>The motor is protected against water splashing from any direction.</li> </ul>
IP55	<ul style="list-style-type: none"> <li>The motor is protected against the ingress of dust, i.e. harmful layers of dust.</li> <li>The motor is protected against water being projected by a nozzle from any direction.</li> </ul>
IP65	<ul style="list-style-type: none"> <li>The motor is completely dust-proof.</li> <li>The motor is protected against water being projected by a nozzle from any direction.</li> </ul>

### System size

The table shows which booster systems are available with alternative enclosure class.

Booster system	Pump type	1	3	5	10	15	20	32	45	64	90	120	150
Hydro Multi-E	CRE	●	●	●	●	●	●						
	CRIE	●	●	●	●	●	●						
	CRNE	●	●	●	●	●	●						
Hydro MPC	CR(E)	●	●	●	●	●	●	●	●	●	●	●	●
	CRI(E)	●	●	●	●	●	●						
	CRN(E)	●	●	●	●	●	●	●	●	●	●	●	●
	CRN(E)	●	●	●	●	●	●	●	●	●	●	●	●

● Available

## Booster systems with alternative colouring

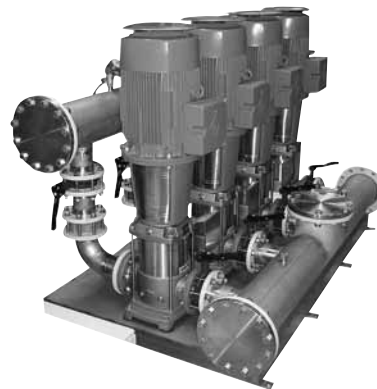

TM04 3240 3908

Fig. 35 Booster system with alternative colouring

We offer custom-built booster systems with all cast parts in any NCS- or RAL-specified colour to suit your requirements!

The colouring takes place by means of electrocoating:

1. Alkaline cleaning
2. Pre-treatment with zinc phosphate coating
3. Cathodic electrocoating (epoxy)
4. Curing of paint film at 200-250 °C.

### System size

The table shows which booster systems are available with alternative colouring.

Booster system	Pump type	1	3	5	10	15	20	32	45	64	90	120	150
Hydro Multi-E	CRE	●	●	●	●	●	●						
	CRIE	●	●	●	●	●	●						
	CRNE	●	●	●	●	●	●						
Hydro MPC	CR(E)	●	●	●	●	●	●	●	●	●	●	●	●
	CRI(E)	●	●	●	●	●	●						
	CRN(E)	●	●	●	●	●	●	●	●	●	●	●	●

● Available



### Alternative diaphragm tanks

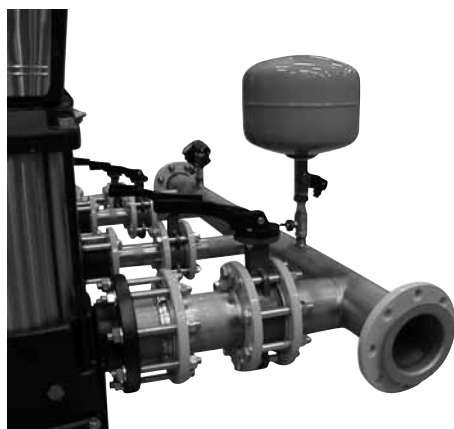

TM04 3483 3908

**Fig. 36** Hydro Booster system with alternative diaphragm tank

If you have special requirements for the diaphragm tank to be connected to your booster system, we have the ideal solution for you!

We offer diaphragm tanks for high pressure, high temperature, or tanks complying with the most strict foodstuff regulation.

For instance, if your application requires compliance with the DVGW drinking water approval, we offer "refix" diaphragm tanks, type DD or DT.

#### Refix DD diaphragm tanks

These diaphragm tanks have capacities from 12 to 33 litres. They are DVGW-approved and have an internal circulation system (anti-legionella bacteria). The bladder is made of butyl and meets the KTW-C requirements.

The tank has an inner and outer epoxy coating against corrosion according to the KTW-A standard.

The optional "flowjet" flow-through valve is ideally suited as shut-off and discharge valve for the tank.



TM04 3885 0509

**Fig. 37** Cutaway view of refix DD tank

#### Refix DT tanks

These diaphragm tanks have capacities from 60 to 3000 litres. They are DVGW-approved and have an internal circulation system (anti-legionella bacteria). The bladder is made out of butyl and meets the German KTW-C requirements.

The tank has an inner and outer epoxy coating against corrosion according to the KTW-A standard.

As standard, the tanks come with a "flowjet" flow-through valve which is ideally suited as shut-off and discharge valve for the tank.

#### Dimensions

##### Refix DD (PN 10/+70 °C)

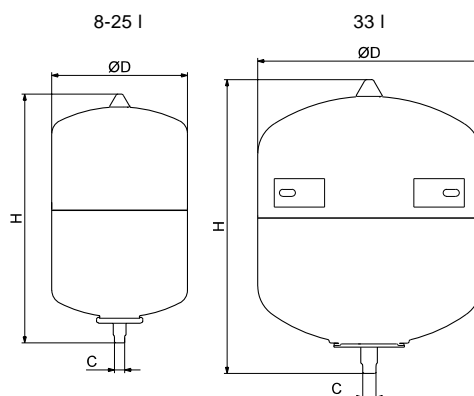

TM04 2504 2608

**Fig. 38** Refix DD diaphragm tanks

##### Refix DD (PN 10/+ 70 °C)

Type	Dimensions			Weight [kg]
	ØD [mm]	H [mm]	C [Inch]	
DD 8	206	335	G 3/4	1.0
DD 12	280	325	G 3/4	2.3
DD 18	280	395	G 3/4	2.8
DD 25	280	515	G 3/4	3.7
DD 33	354	465	G 3/4	6.6

**Note:** These diaphragm tanks are fitted onto the manifold of the booster system by means of a threaded connection.

### Refix DT (PN 10/+70 °C)

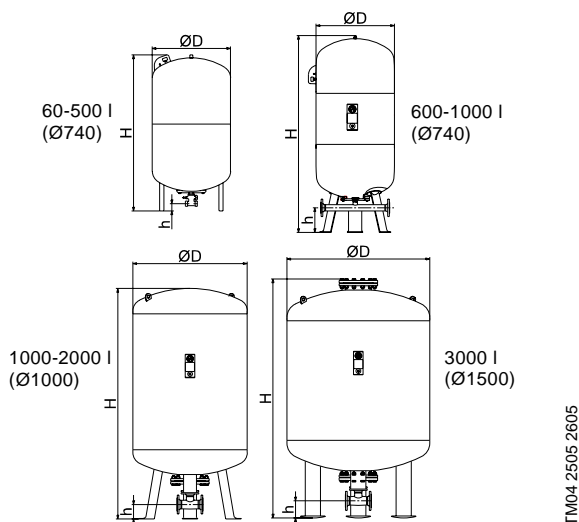

Fig. 39 Refix DT diaphragm tanks

### Refix DT (PN 10)

Type	Dimensions			Weight [kg]	Flowjet
	ØD [mm]	H [mm]	h [mm]		
DT 5 60	409	766	80	15	Rp 1 1/4
DT 5 80	480	750	65	17	Rp 1 1/4
DT 5 100	480	835	65	20	Rp 1 1/4
DT 5 200	635	975	80	47	Rp 1 1/4
DT 5 300	635	1275	80	53	Rp 1 1/4
DT 5 400	740	1245	70	70	Rp 1 1/4
DT 5 500	740	1475	70	79	Rp 1 1/4
DT 5 600	740	1860	235	155	DN 50
DT 5 800	740	2325	235	195	DN 50
DT 5 1000	740	2604	235	228	DN 50
DT 5 1000	1000	2000	160	424	DN 65
DT 5 1500	1200	2000	160	539	DN 65
DT 5 2000	1200	2450	160	714	DN 65
DT 5 3000	1500	2520	190	1054	DN 65

**Note:** These diaphragm tanks are to be installed on feet beside the booster system and connected to the booster system by means of a flexible hose.

### Refix DT (PN 16 /+70 °C)

Type	Dimensions			Weight [kg]	Flowjet
	ØD [mm]	H [mm]	h [mm]		
DT 5 80	480	750	65	27	Rp 1 1/4
DT 5 100	480	835	65	29	Rp 1 1/4
DT 5 200	635	975	80	55	Rp 1 1/4
DT 5 300	635	1275	80	57	Rp 1 1/4
DT 5 400	740	1395	235	109	DN 50
DT 5 500	740	1615	235	121	DN 50
DT 5 600	740	1860	235	165	DN 50
DT 5 800	740	2325	235	215	DN 50
DT 5 1000	740	2604	235	241	DN 50
DT 5 1000	1000	2000	160	530	DN 65
DT 5 1500	1200	2000	160	685	DN 65
DT 5 2000	1200	2450	160	895	DN 65
DT 5 3000	1500	2520	190	1240	DN 65

### Break tank, type VB

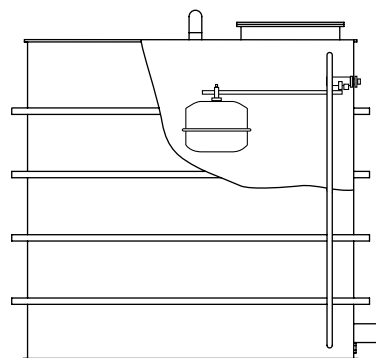

Fig. 40 Break tank, type VB

If you require closed and pressureless tanks for your drinking water system, we have the ideal solution for you.

We offer closed pressureless tanks with integrated water-level indication for liquid temperatures up to +50 °C.

The tanks are made of black polyethylene (PE-HD) and have built-in aeration/vent duct, inspection cover and drain plug.

They can be equipped with inlet and dry-running fittings.

#### Installation

The tank must be installed on a level, horizontal and frost-proof surface.

**Note:** There must be adequate space for inspection of the tank. Pipes to and from the tank must not stress the tank unnecessarily.

If the inlet pressure to the tank is higher than 5 bar, a pressure-reducing valve must be fitted on the tank inlet to prevent damage of the tank.

### Dimensions

Description	Break tank, type VB						
	300 R	500 R	800 R	1000 E	1500 E	2000 E	3000 E
Nominal volume [l]	300	500	800	1000	1500	2000	3000
Effective volume [l]	260	410	760	940	1350	1750	2590
Tank shape	Cylindrical			Rectangular			
Inlet	R 1	R 1 1/4	R 1 1/2	R 2	R 2	R 2	R 2
Outlet	R 1 1/2	R 2	R 2	DN 80	DN 80	DN 80	DN 80
Overflow	DN 65	DN 100	DN 100	DN 100	DN 100	DN 100	DN 100
Dry-running protection	R 1/2	R 1/2	R 1/2	R 1/2	R 1/2	R 1/2	R 1/2
Drain hole	R 1	R 1 1/2	R 1 1/2	R 1 1/2	R 1 1/2	R 1 1/2	R 1 1/2
Manhole*	DN 250	DN 250	DN 250	DN 500	DN 500	DN 500	DN 500
Diameter [mm]	735	900	900				
Height [mm]	1100	1155	1800	1650	1650	1650	1650
Width [mm]				820	850	850	850
Length [mm]				1320	1770	2220	3120
Dry weight [kg]	25	35	50	100	130	150	230

\* With strap

### Float valve for VB break tanks

A float valve is available as an accessory for VB break tanks.

### Specification

Maximum inlet pressure: 6 bar  
 Maximum temperature: +60 °C  
 Valve material: Brass  
 Bar and level switch material: Stainless steel.

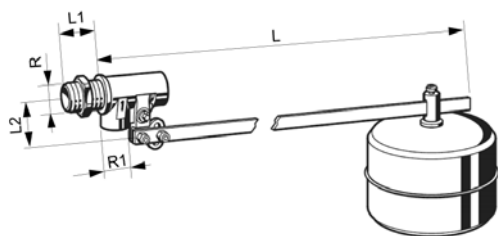

TM04 4027 0509

Fig. 41 Float valve for VB break tank

Pipe connection		Flow [m <sup>3</sup> /h]		Dimensions [mm]		
Inlet R	Outlet R1	1.5 bar	3.0 bar	L	L1	L2
2	1 1/2	21.0	30.1	735	151	45

### System size

The table shows for which booster systems break tanks are available.

Booster system	Pump type	1	3	5	10	15	20	32	45	64	90	120	150
Hydro Multi-E	CRE	●	●	●	●	●	●						
	CRIE	●	●	●	●	●	●						
	CRNE	●	●	●	●	●	●						
Hydro MPC	CR(E)	●	●	●	●	●	●	●	●	●	●	●	●
	CRI(E)	●	●	●	●	●	●						
	CRN(E)	●	●	●	●	●	●	●	●	●	●	●	●

● Available

### Product numbers

Type	Product number
VB 300 R	00ID7649
VB 500 R	00ID7650
VB 800 R	00ID7651
VB 1000 E	00ID7692
VB 1500 E	00ID7693
VB 2000 E	00ID7694
VB 3000 E	00ID8709

## Alternative pump head positions

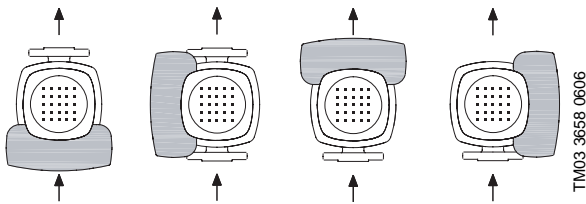

Fig. 42 Pump head positions

As standard, the pump heads of the CR pumps of the Hydro booster systems are mounted so that the air vent screw is in line with the discharge port.

Alternatively, pump heads can be mounted in three other positions in steps of 90 °.

## Stainless steel control cabinets



Fig. 43 Control cabinets in stainless steel

As standard, control cabinets for Hydro Multi-E and Hydro MPC booster systems are of the following materials.

### Hydro Multi-E

Control cabinet made of white or gray composite material.

### Hydro MPC

Control cabinet made of steel and treated with either RAL 7032 or RAL 7035.

Alternatively, we offer untreated control cabinets made of stainless steel EN DIN 1.4301 to meet special requirements.

## Control cabinets with cooling units



Fig. 44 Control cabinets with cooling units

Control cabinets with cooling units are recommended in situations where the control cabinet of the Hydro booster system is placed in ambient temperatures close to or above +40 °C.

For installations with high ambient temperatures, we offer flexible and vertically mounted cooling units with these benefits:

- They ensure sufficient cooling of the electronics inside the cabinet.
- They prolong the life of the electronics.
- They save energy.
- They prevent downtime.

The control cabinet is cooled indirectly by the cooling unit mounted on the side of the control cabinet. Fig. 45 shows how the control cabinet is cooled.

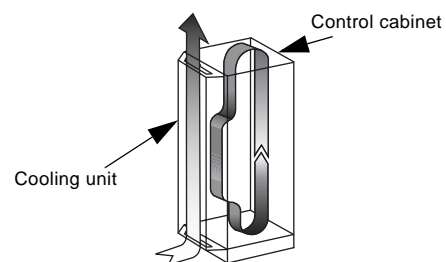

Fig. 45 Air flow inside control cabinet and cooling unit

If cooling of the control cabinet is relevant to your pressure boosting application, we will find a solution that suits you!

### Customised nameplate

We offer additional customised nameplates attached to the booster system, such as these:

- Nameplate supplied by you
- Grundfos nameplate customised in terms of a specific duty point.
- Grundfos nameplate with a tag number.

### Threaded flange

If you want to change the threaded manifold connection on your Hydro booster system into a DIN connection, we offer the following threaded flanges:

Size	Pressure class	Material	Standard	Product number
DN 32 x R 1	PN 10/16	1.4571	DIN 2566	00ID7617
DN 40 x R 1 1/2				00ID7618
DN 50 x R 2				00ID7619
DN 65 x R 2 1/2				00ID7620

### OEM solutions

We offer a wide range of OEM-specified solutions for our Hydro booster systems.

Give us with a detailed description of your requirements, and we will get down to work - for you!

### Expansion joints

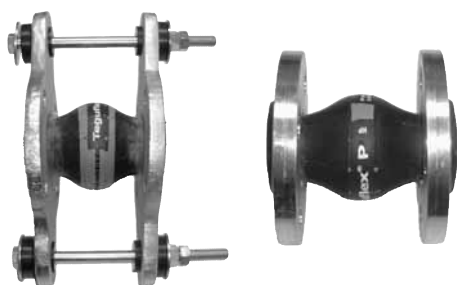

TM02 4979 1902 - TM02 4981 1902

**Fig. 46** Examples of rubber bellows expansion joints with and without limiting rods

Expansion joints are installed for the following reasons:

- absorption of expansions/contractions in the pipework caused by changing liquid temperature
- reduction of mechanical strains in connection with pressure surges in the pipework
- isolation of mechanical structure-borne noise in the pipework (only rubber bellows expansion joints).

**Note:** Expansion joints must **not** be installed to compensate for inaccuracies in the pipework such as centre displacement of flanges.

It is advisable to fit expansion joints at a distance of minimum 1 to 1 1/2 x DN diameter from the manifold on the suction as well as on the discharge side. This prevents the development of turbulence in the expansion joints, resulting in better suction conditions and a minimum pressure loss on the pressure side.

**Note:** The pipes should be anchored to prevent stress on the expansion joints and the pump. Follow the supplier's instructions and pass them on to advisers or pipe installers.

Depending on the size of the Hydro booster system, we offer to types of expansion joint:

- rubber bellow expansion joints
- expansion joints with limiting rods.

#### Rubber bellow expansion joints

- For drinking water systems with a liquid temperature up to maximum +90 °C.
- Incorporates two flat sealing hexagon nipples.
- Port-to-port length without thread: 130 mm.
- Shore hardness A 55.
- Union nut and screw-in parts made of malleable cast iron, zinc-plated.

#### Expansion joints with limiting rod

- For drinking water systems with a liquid temperature up to maximum +90 °C.
- DVGW-approved.
- Port-to-port length: 130 mm.

#### Dimensions

##### Rubber bellow expansion joints

Connection	Max. operating conditions						Port-to-port length [mm]	Bellow diameter [mm]	Weight [kg]	Product number
	[bar]	[°C]	[bar]	[°C]	[bar]	[°C]				
R 1	16	20	12	50	10	90	192	65	0.85	00ID9054
R 1 1/4							196	78	1.5	00ID9055
R 1 1/2							202	90	1.9	00ID9056
R 2							215	109	2	00ID9057

## Expansion joints with limiting rods

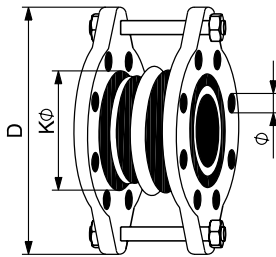

TM04 3174 3808

**Fig. 47** Dimensional sketch of expansion joint with limiting rods

## Flanges of steel 37-2

Size	Pressure class	Flange dimensions [mm]			Product number
		D	kφ	L x φ	
DN 40	PN 16	150	110	4 x 18	00ID9307
DN 50		165	125		00ID6863
DN 65		185	145		00ID6864
DN 80		200	160	8 x 18	00ID6865
DN 100		220	180		00ID6866
DN 150		285	240		91070992
DN 200		340	295		12 x 22

## Flanges of stainless steel, DIN/EN 1.4571

Size	Pressure class	Flange dimensions [mm]			Product number
		D	kφ	L x φ	
DN 32	PN 16	140	100	4 x 18	91074487
DN 40		150	110		91074488
DN 50		165	125		91074489
DN 65		185	145	8 x 18	91074490
DN 80		200	160		91074491
DN 100		220	180		91074492
DN 150		285	240		91074493
DN 200		340	295	12 x 22	91074494

## Stainless steel mechanical filter

For the collection of fibres and solids that may harm the pump or the system we offer stainless steel mechanical filters mounted on the suction side of each pump.

### Specification

Material, housing	Cast iron or stainless steel
Material, screen	Stainless steel EN DIN 1.4301
Rated pressure [bar]	6/16/25/40
Connection	DN 15 to DN 300

### Plug-and-pump solutions for booster systems with CR(I)E pumps

To facilitate electrical installation and service of custom-built three-phase Hydro MPC-E or Hydro Multi-E booster systems up to 7.5 kW, we offer motor terminal boxes with a detachable cable inlet bar.

When the cable inlet bar is removed, it is possible to disconnect all electrical connections to the motor.

Fig. 48 shows the location of the detachable cable inlet bar on the motor terminal box as well as plugs for mains connection, sensor and communication.

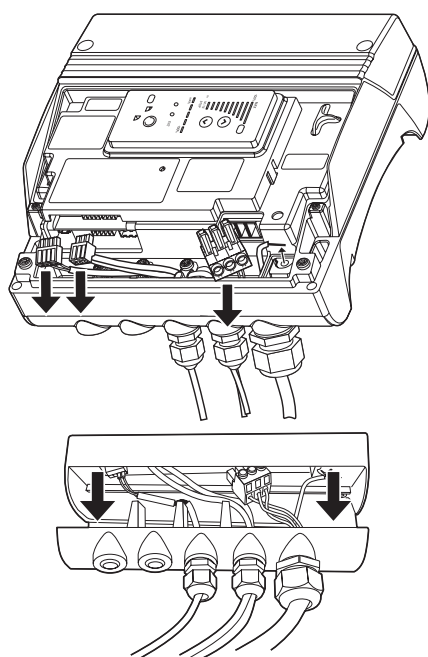

TM03 1964 3405 - TM03 1962 3405

**Fig. 48** Location of the detachable cable inlet bar

### Booster systems with oversize motors



TM03 1711 2805

**Fig. 49** Grundfos motor

We recommend a Hydro booster system with oversize motors if operating conditions deviate from those stated in these data booklets:

- Hydro MPC
- Hydro Multi-E.

We especially recommend oversize motors in these cases:

- The booster system is installed at an altitude above 3500 metres.
- The ambient temperature exceeds +60 °C.

We offer the oversize motors below.

#### Mains-operated motors

Oversize motors (3-phase)	
2-pole	4-pole
	0.37
0.55	0.55
0.75	0.75
1.1	1.1
1.5	1.5
2.2	2.2
3.0	3.0
4.0	4.0
5.5	5.5
7.5	7.5
11	11
15	15
18.5	18.5
22	
30	
37	
45	
55	
75	

### Motors with integrated frequency converter

Oversize motors (3-phase)	
2-pole	4-pole
	0.37
0.55	0.55
0.75	0.75
1.1	1.1
1.5	1.5
2.2	2.2
3.0	3.0
4.0	4.0
5.5	5.5
7.5	
11	
15	
18.5	
22	



## Booster systems with undersize motors



TM03 1711 2805

**Fig. 50** Grundfos motor

We recommend a Hydro booster system with undersize motors if operating conditions deviate from those stated in these data booklets:

- Hydro MPC
- Hydro Multi-E.

We especially recommend undersize motors if the duty point is constant and the flow rate is significantly lower than the maximum recommended flow rate.

We offer the undersize motors below.

### Mains-operated motors

Undersize motors (3-phase)	
2-pole	4-pole
	0.25
0.37	0.37
0.55	0.55
0.75	0.75
1.1	1.1
1.5	1.5
2.2	2.2
3.0	3.0
4.0	4.0
5.5	5.5
7.5	7.5
11	
15	
18.5	
22	
30	
37	
45	
55	

## Motors with integrated frequency converter

Undersize motors (3-phase)	
2-pole	4-pole
	0.25
0.37	0.37
0.55	0.55
0.75	0.75
1.1	1.1
1.5	1.5
2.2	2.2
3.0	3.0
4.0	4.0
5.5	
7.5	
11	
15	
18.5	

## Booster systems with 4-pole motors



TM03 1711 2806

**Fig. 51** 4-pole motor

As standard, All Hydro booster systems are fitted with 2-pole motors.

If you have strict requirements for a low sound pressure level, or inlet conditions are poor, you may consider a custom-built Hydro booster system with 4-pole motors.

For further information about CR pumps with 4-pole motors, see the data booklet "CR, CRI, CRN, CRT, CRE, CRIE, CRNE, CRTE - custom-built pumps" in WebCAPS.

Motor

## Hydro Multi-S with anti-condensation heater



TM03 2440 4305

**Fig. 52** Anti-condensation heater

If your application involves the risk of condensation in the motor of the pumps, we recommend a custom-built booster system where the motors have anti-condensation heaters on the stator coil ends.

**Note:** We offer Hydro Multi-S booster systems with motors with anti-condensation heaters up to 11 kW (one per pump).

A condensation heater keeps the motor temperature higher than the ambient temperature and prevents condensation.

High humidity may cause condensation in the motor. Slow condensation occurs as a result of a decreasing ambient temperature; rapid condensation occurs as a result of shock cooling caused by direct sunlight followed by tropical rain.

**Note:** Rapid condensation is not to be confused with the phenomenon which occurs when the pressure inside the motor is lower than the atmospheric pressure. In such cases moisture is sucked from the atmosphere into the motor through bearings housings etc.

In applications with constant high humidity levels above 85 %, the drain holes in the drive-end flange must be open. This changes the enclosure class to IP44.

If IP55 protection is required due to operation in dusty environments, it is advisable to install motors with anti-condensation heaters.

The figure below shows a typical circuit of a three-phase motor with anti-condensation heater.

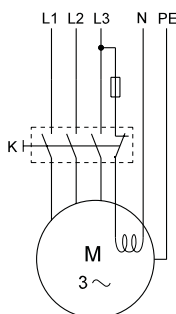

TM03 4058 1406

**Fig. 53** Three-phase motor with anti-condensation heater

### Key

Symbol	Description
K	Contactor
M	Motor

**Note:** Connect the anti-condensation heater to the supply voltage so that it is on when the motor is switched off.

The following motor sizes are available with anti-condensation heater:

#### 1 x 220-250 V, 50/60 Hz

Motor size [kW]	Power of heating unit [W]
0.37 - 3.0	23
4.0 - 7.5	31
11	38

## Booster systems with special voltage



TM03 1711 2805

**Fig. 54** Motor for special supply voltage

As standard, we offer Hydro booster systems with the following standard supply voltages:

Frequency [Hz]	Voltage [V]
50 Hz	3 x 200 V, 50 Hz, PE
	3 x 220 V, 50 Hz, PE
	3 x 380 V, 50 Hz, N, PE
	3 x 400 V, 50 Hz, N, PE
	3 x 415 V, 50 Hz, N, PE
	3 x 380 V, 50 Hz, PE
60 Hz	3 x 400 V, 50 Hz, PE
	3 x 415 V, 50 Hz, PE
	3 x 200 V, 60 Hz, PE
	3 x 208 V, 60 Hz, PE
	3 x 220 V, 60 Hz, PE
	3 x 230 V, 60 Hz, PE
	3 x 240 V, 60 Hz, PE
	3 x 380 V, 60 Hz, N, PE
	3 x 400 V, 60 Hz, N, PE
	3 x 415 V, 60 Hz, N, PE
	3 x 380 V, 60 Hz, PE
	3 x 400 V, 60 Hz, PE
3 x 415 V, 60 Hz, PE	
3 x 460 V, 60 Hz, PE	
3 x 575 V, 60 Hz, PE	

Other supply voltages are available on request. Please contact us for further information.

## Alternative motor brands

We offer custom-built booster systems with pumps fitted with a motor of any make which can fulfil the requirements to these aspects:

- flange dimensions
- bearing specifications
- pump shaft.

Alternatively, Grundfos Hydro booster systems can be supplied with pumps without a motor.

## cURus -, UR -, CSA approved motors



TM03 1711 2805

**Fig. 55** cURus -, UR -, CSA approved motor

We offer custom-built booster systems with mains-operated pumps fitted with motors with these approvals:

Approval	Motor power - P <sub>2</sub> [kW]
cURus	0.37 - 7.5
UR	11 - 75
CSA	11 - 75

## Other motor approvals

We offer a wide range of motor approvals such as these:

- CCC
- C-tick
- GOST
- BΔ
- TSU
- METI/JQA
- CB
- TSE
- SASO.

### Customer-specified equipment

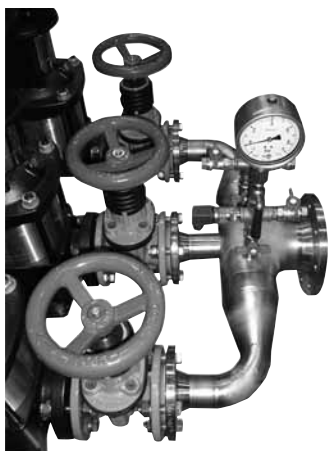

TM04 3250 3908

**Fig. 56** Example of customer-specified equipment

We offer Hydro booster systems with equipment specified to meet your needs. Give us a detailed description of your requirements, and we will get down to work - for you!

### 2-valve manifold



TM04 3249 3908

**Fig. 57** 2-valve manifold

The 2-valve isolating and venting manifold is mainly used for calibration purposes. It is often referred to as a "block 'n' bleed" valve.

The 2-valve manifold will isolate instruments such as pressure transmitters or pressure switches from the process and allow venting of the instrument for calibration or removal from the circuit without effecting the process or application, and/or sampling, etc.

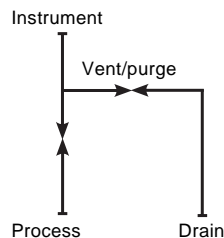

TM04 3171 4308

**Fig. 58** Schematic view of 2-valve manifold

#### Temperature range

20 to +200 °C.

#### Materials

Designation	Material	EN/DIN	AISI/ASTM
Body			
Stem	Stainless steel	1.4401	AISI 316
Handle			
Gland seal	RTFE/Graphoil		

#### Connections

Standard NPT 1/2" inlet x 1/2" outlet with a 1/4" vent port supplied plugged as standard for safety.

#### System size

Booster system	Pump type	1	3	5	10	15	20	32	45	64	90	120	150
Hydro Multi-E	CRE	●	●	●	●	●	●						
	CRIE	●	●	●	●	●	●						
	CRNE	●	●	●	●	●	●						
Hydro MPC	CR(E)	●	●	●	●	●	●	●	●	●	●	●	●
	CR(I)(E)	●	●	●	●	●	●						
	CRN(E)	●	●	●	●	●	●	●	●	●	●	●	●

● Available

## Dimensions

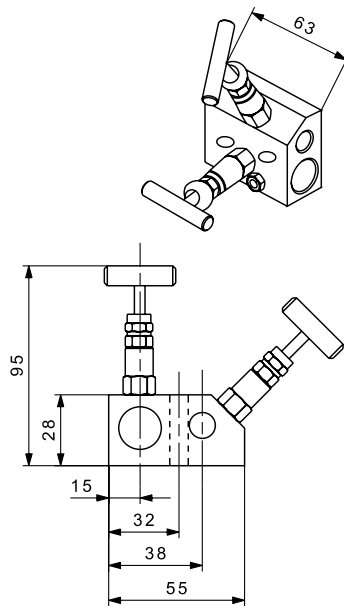

TM04 3172 4308

Fig. 59 Dimensional sketch of 2-valve manifold

## Swivel adapters



TM04 3252 3908

Fig. 60 Swivel adapter for pressure gauge

Swivel adapters are used when threaded connection of pressure gauge tapping in the manifold differs from the threaded connection of an alternative pressure gauge.

The swivel adaptor allows the direct connection of a pressure gauge to the booster system with the dial in the correct orientation.

These adaptors have a built-in O-ring seal for pressure gauges with sealing nipple according to DIN 16288.

## Specifications

Main characteristics	
Temperature range	-20 to +100 °C
Materials	
Body	Steel 9SMn28K/stainless steel AISI 316
Seal	Nitrile

## System size

Booster system	Pump type	1	3	5	10	15	20	32	45	64	90	120	150
Hydro Multi-E	CRE	●	●	●	●	●	●						
	CRIE	●	●	●	●	●	●						
	CRNE	●	●	●	●	●	●						
Hydro MPC	CR(E)	●	●	●	●	●	●	●	●	●	●	●	●
	CRl(E)	●	●	●	●	●	●						
	CRN(E)	●	●	●	●	●	●	●	●	●	●	●	●

● Available

## Dimensions

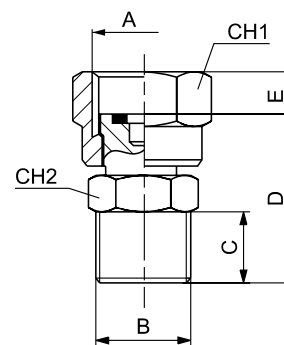

TM04 3173 4308

Fig. 61 Dimensional sketch of swivel adapter

## Dimensions

Parallel threads have a 60 ° internal cone.

Type	A	B	C	D	E	CH1	CH2	Weight [kg]
44	1/4" parallel	1/4" parallel/taper	13	27	9.5	18	17	0.04
42	1/4" parallel	1/2" taper	16	31	9.5	18	22	0.068
24	1/2" parallel	1/4" taper	13	31	11	27	22	0.09
22	1/2" parallel	1/2" taper	16	34	11	27	22	0.1

## Product numbers

Type	A	B	Product number
44	1/4" parallel	1/4" parallel/taper	96762312
42	1/4" parallel	1/2" taper	96635187
24	1/2" parallel	1/4" taper	96842455
22	1/2" parallel	1/2" taper	96762291

### Alternative pressure transmitter



TM04 3247 3908

**Fig. 62** Trafag pressure transmitter

As standard, Grundfos Hydro booster systems are fitted with Danfoss MBS 3000 pressure transmitters.

If you require pressure transmitters of another brand, we offer of the following brands and series

- Trafag (NAT series)
- Endress & Hauser (Ceraphant T PTP31 series)
- Druck (PTX7517 series)
- IFM (PE7004 or PN3004 series).

Brand	Danfoss (standard)	TRAFAG	Endress+Hauser	Druck	IFM	
<b>Main characteristics</b>						
Sensor type					PE7004	PN3004
Measuring range [bar] $P_e^{(1)}$	0-40	0-40	0-40	0-40	1-10	-1-10
Signal output	4-20 mA	●	●	●	●	
	0-10 VDC	●	●	-	-	●
Accuracy	± 0.5 % FS	± 0.5 % FS	± 0.5 % FS	± 0.1 % FS	± 0.5 % FS	± 0.5 % FS
Output/supply voltage	4-20 mA	9..32 VDC	9..32 VDC	12..30 VDC	9..30 VDC	NA
	0-10 VDC	15..30 VDC	15..32 VDC	-	-	NA
Response time	< 4 ms	1 s	20 ms	500 ms	NA	< 3 ms
<b>Environmental conditions</b>						
Operating temperature	-40 to +85 °C	-25 to +85 °C	-40 to +85 °C	-40 to +100 °C	-20 to +80 °C	-20 to +80 °C
Liquid temperature	-40 to +85 °C	-25 to +125 °C	-40 to +100 °C	-40 to +120 °C	-25 to +80 °C	-25 to +80 °C
Enclosure class	IP65	IP65	IP65	IP65	IP67	IP65
Vibration	20 g	25 g	20 g	NA	20 g	20 g
	(25..2000 Hz)	(20..2000 Hz)	(10..2000 Hz)		(10..2000 Hz)	(10..2000 Hz)
Shock	500 g / 1 ms	100 g / 11 ms	NA	100 g / 11 ms	50 g / 11 ms	50 g / 11 ms
<b>Mechanical data</b>						
Connection	G 1/4	G 1/4	G 1/2	G 1/4	G 1/4	G 1/4
Sensor	1.4404	1.4542	1.4404	1.4404	AISI 316S12	AISI 303S22
	AISI 316L	AISI 630	AISI 316L	AISI 316L		
Housing	1.4404	1.4301	1.4404	1.4404	AISI 316S12	AISI 316S12
	AISI 316L	AISI 304	AISI 316L	AISI 316L		

<sup>(1)</sup> Relative/gauge

## Product numbers

Brand	Sensor type	Measuring range [bar]	Product number
TRAFAG	NAT2.5A	0 - 2.5	96690969
	NAT4.0A	0 - 4	96690970
	NAT6.0A	0 - 6	96691002
	NAT10.0A	0 - 10	96691003
	NAT16.0A	0 - 16	96691004
	NAT25.0A	0 - 25	96691005
Endress+Hauser	Ceraphant T PTP31 A	0 - 4	96763127
	Ceraphant T PTP31 B	0 - 10	96837391
	Ceraphant T PTP31 B	0 - 40	96837394
	Ceraphant T PTP31 C	0 - 10	96837393
	Ceraphant T PTP31 C	0 - 40	96837396
Druck	PTX 7517	0 - 2	96981529
	PTX 7517	0 - 10	96981525
	PTX 7517	0 - 16	96981527
	PTX 7517	0 - 25	96981531
IFM	PE7004	0 - 10	96782879
	PN3004	-1 - 10	96782880

### Flowmeter



TM04 3482 4508

Fig. 63 Flowmeter

For applications involving constant flow control, we offer custom-built booster systems with compact electromagnetic ABB COPA-XE flowmeters.

Main characteristics	
Measuring range	0.5 - 10 m/s
Accuracy	0.5 % of rate
Connection	DIN flange DN 50-300
Pressure class	PN 10-40
Conductivity	> 5 µS/cm (20 µS/cm for demineralised water)
Process connection material	Stainless steel, 1.4571 (AISI 316Ti)
Flange material	St 37-2
Liner	Hard/soft rubber PTFE, PFA
Enclosure class	IP67
Liquid temperature	-25 to +130 °C
Approvals	
EEX design	TÜV 97, ATEX 1173X
Certifiable	Cold and hot water, liquids other than water
Press. Equip. Dir. 97/23/EG	Conformity Evaluation per Category III, Fluid group 1
Converter	
Supply voltage	AC 100-230 V (-15/+10 %) / AC 16.8-26.4 V / DC 16.8-31.2 V
Current output	0/4-20 mA
Pulse output	Active 24 V DC pulse or passive optocoupler
Ext. zero return	Optocoupler input
Ext. totaliser reset	Optocoupler input
Forward/reverse metering	Signal over optocoupler output
Empty pipe detector	From DN 10: 3/8", signal over optocoupler
Self-monitor	Yes
Local display/totalisation	Yes
Housing	Converter housing of aluminium, converter of stainless steel (option)
Communication	PROFIBUS

### System size

Booster system	Pump type	1	3	5	10	15	20	32	45	64	90	120	150
Hydro Multi-E	CRE	●	●	●	●	●	●						
	CRIE	●	●	●	●	●	●						
	CRNE	●	●	●	●	●	●						
	CR(E)	●	●	●	●	●	●	●	●	●	●	●	●
Hydro MPC	CRI(E)	●	●	●	●	●	●						
	CRN(E)	●	●	●	●	●	●	●	●	●	●	●	●
	CRN(E)	●	●	●	●	●	●	●	●	●	●	●	●

● Available

### Stainless steel pressure gauge



TM04 3251 3908

Fig. 64 Pressure gauge (Ø100 mm)

We offer custom-built booster systems with a Ø100 mm stainless steel pressure gauge.

Parameter	Specification
Main characteristics	
Design	EN 837-1
Nominal size	100 mm
Accuracy class	1.0
Enclosure class	IP65 (EN 60529/IEC 529)
Pressure conditions	
Working pressure	
- Steady	Full scale value
- Fluctuating	0.9 x full scale value
- Short time	1.3 x full scale value
Operating temperature	
Ambient temperature	-40 to +60 °C without liquid filling -20 to +60 °C with glycerine filling
Liquid temperature <sup>(1)</sup>	Max. 200 °C without liquid filling Max. 100 °C with liquid filling
Materials	
Connection	Stainless steel AISI 316L
Housing	Natural finish stainless steel <sup>(2)</sup>
Window	Laminated safety glass
Pointer	Black aluminium
Dial	White aluminium with black lettering
Movement	Stainless steel
Bezel ring	Cam ring (bayonet type), natural finish stainless steel
Connection	
Connection	G 1/2 B (male), 22 mm flats

<sup>1)</sup> **Note:** If the temperature of the pressure element deviates from reference temperature (+20 °C): Max. ± 0.4 %/10 K of true scale value.

<sup>2)</sup> Pressure relief in housing back, scale ranges ≤ 10 bar with compensating valve to vent housing.

### System size

Booster system	Pump type	1	3	5	10	15	20	32	45	64	90	120	150
Hydro Multi-E	CRE	●	●	●	●	●	●						
	CRIE	●	●	●	●	●	●						
	CRNE	●	●	●	●	●	●						
Hydro MPC	CR(E)	●	●	●	●	●	●	●	●	●	●	●	●
	CRI(E)	●	●	●	●	●	●						
	CRN(E)	●	●	●	●	●	●	●	●	●	●	●	●

● Available



### Dimensions

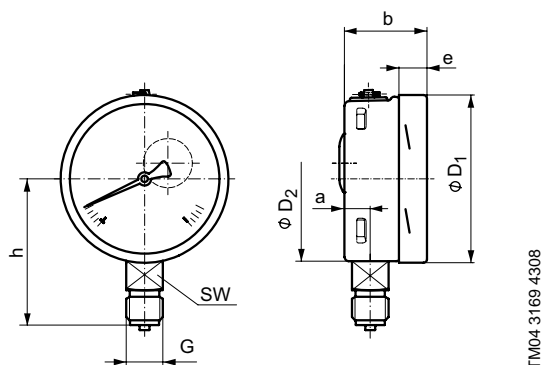

**Fig. 65** Dimensional sketch of pressure scale with radial bottom pressure entry (type LM)

TM04 3169 4308

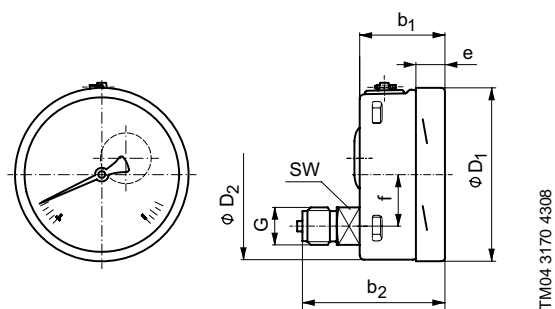

**Fig. 66** Dimensional sketch of pressure scale with lower back pressure entry (type LBM)

TM04 3170 4308

Dimensions in mm											Weight	
a	b	b <sub>1</sub>	b <sub>2</sub>	D <sub>1</sub>	D <sub>2</sub>	e	f	G	h ± 1	SW	Without glycerine	With glycerine
15.5	49.5	49.5	83	101	99	17.5	30	G 1/2 B	87	22	0.6	0.9

### Sampling valve



**Fig. 67** Sampling valve

TM04 3485 4508

In water distribution applications, a strong focus is put on hygiene. It is often a requirement that authorities have access to taking samples of the water being distributed.

To meet such requirements, we offer custom-built booster systems with a sterilisable sampling valve which enables testing of the microbiological and chemical quality of the water.

### Valve specifications

Maximum operating temperature: +90 °C.

Maximum operating pressure: 16 bar.

Installation: Vertical/horizontal.

### Materials

Designation	Material
Housing	Red brass
Top section	Red brass/brass
Spindle	Red brass
Top section seal, spindle seal	PTFE
Seat seal	PTFE
Outlet pipe	Stainless steel
Sleeve nut	Brass
Seal	EPDM

### System size

Booster system	Pump type	1	3	5	10	15	20	32	45	64	90	120	150
Hydro Multi-E	CRE	•	•	•	•	•	•						
	CRIE	•	•	•	•	•	•						
	CRNE	•	•	•	•	•	•						
Hydro MPC	CR(E)	•	•	•	•	•	•	•	•	•	•	•	•
	CRI(E)	•	•	•	•	•	•						
	CRN(E)	•	•	•	•	•	•	•	•	•	•	•	•

• Available

### Dimensions

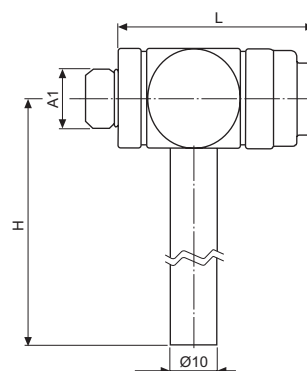
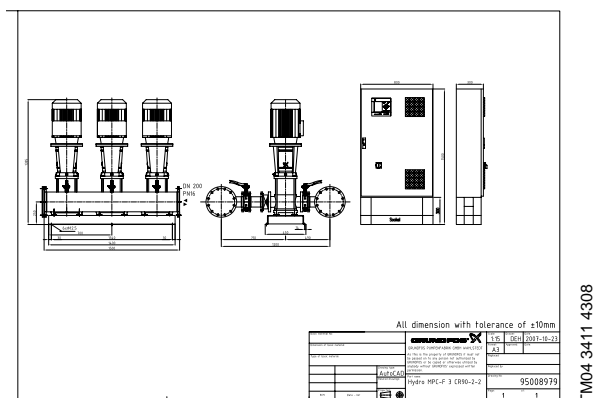

**Fig. 68** Dimensional sketch of sampling valve

TM04 3481 4508

Nominal width	H	L	A1	Weight
DN 6	125	43	G 1/4	0.208
DN 10	125	56.5	G 3/8	0.244

## CAD drawings

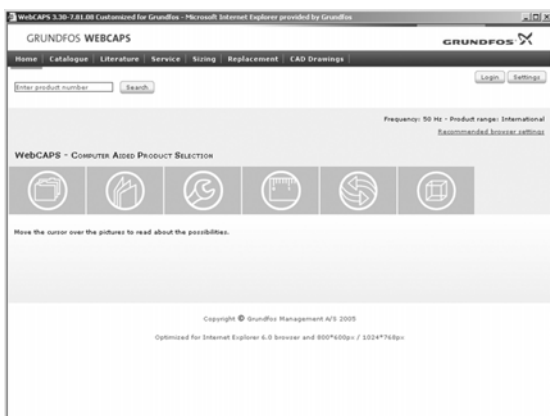

**Fig. 69** CAD drawing for Hydro MPC

If you require AutoCAD drawings of our Hydro booster systems, we can provide such drawings.

We offer AutoCAD drawings in .dxf or .dwg format of all standard and custom-built systems.

## WebCAPS



WebCAPS is a **Web-based Computer Aided Product Selection** program available on [www.grundfos.com](http://www.grundfos.com).

WebCAPS contains detailed information on more than 185,000 Grundfos products in more than 20 languages.

In WebCAPS, all information is divided into 6 sections:

- Catalogue
- Literature
- Service
- Sizing
- Replacement
- CAD drawings.

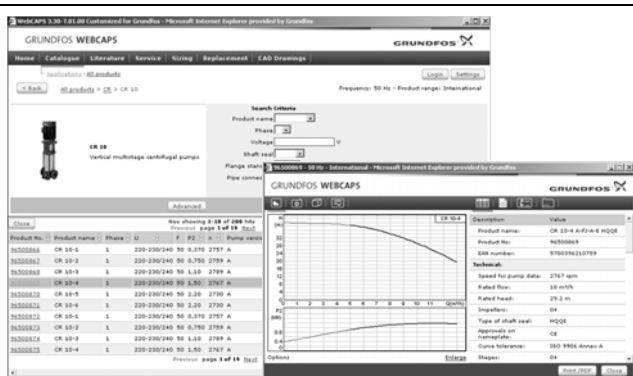

### Catalogue

This section is based on fields of application and pump types, and contains

- technical data
- curves (QH, Eta, P1, P2, etc.) which can be adapted to the density and viscosity of the pumped liquid and show the number of pumps in operation
- product photos
- dimensional drawings
- wiring diagrams
- quotation texts, etc.

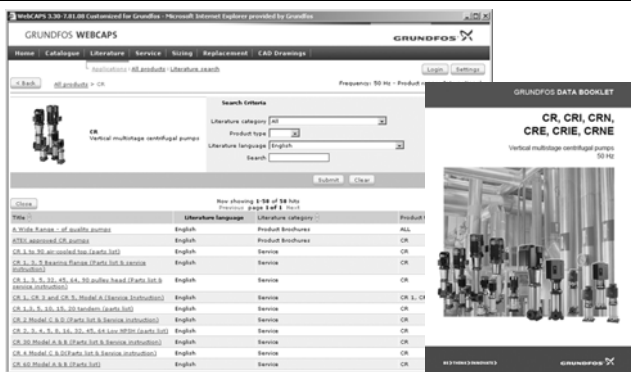

### Literature

In this section you can access all the latest documents of a given pump, such as

- data booklets
- installation and operating instructions
- service documentation, such as Service kit catalogue and Service kit instructions
- quick guides
- product brochures.

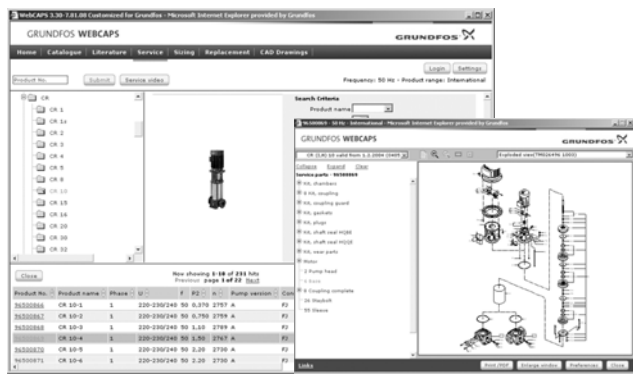

### Service

This section contains an easy-to-use interactive service catalogue. Here you can find and identify service parts of both existing and discontinued Grundfos pumps.

Furthermore, this section contains service videos showing you how to replace service parts.



### Sizing

This section is based on different fields of application and installation examples, and gives easy step-by-step instructions in how to

- select the most suitable and efficient pump for your installation
- carry out advanced calculations based on energy consumption, payback periods, load profiles, life cycle costs, etc.
- analyse your selected pump via the built-in life cycle cost tool
- determine the flow velocity in wastewater applications, etc.



### Replacement

In this section you find a guide to selecting and comparing replacement data of an installed pump in order to replace the pump with a more efficient Grundfos pump. The section contains replacement data of a wide range of pumps produced by other manufacturers than Grundfos.

Based on an easy step-by-step guide, you can compare Grundfos pumps with the one you have installed on your site. When you have specified the installed pump, the guide will suggest a number of Grundfos pumps which can improve both comfort and efficiency.



### CAD drawings

In this section it is possible to download 2-dimensional (2D) and 3-dimensional (3D) CAD drawings of most Grundfos pumps.

These formats are available in WebCAPS:

- 2-dimensional drawings:
- .dxf, wireframe drawings
  - .dwg, wireframe drawings.
- 3-dimensional drawings:
- .dwg, wireframe drawings (without surfaces)
  - .stp, solid drawings (with surfaces)
  - .eprt, E-drawings.

## WinCAPS



Fig. 70 WinCAPS CD-ROM

WinCAPS is a **Windows-based Computer Aided Product Selection** program containing detailed information on more than 185,000 Grundfos products in more than 20 languages.

The program contains the same features and functions as WebCAPS, but is an ideal solution if no Internet connection is available.

WinCAPS is available on CD-ROM and updated once a year.







96881732 0709	GB

Subject to alterations.